

Vacuum Solutions

Application Support

Service

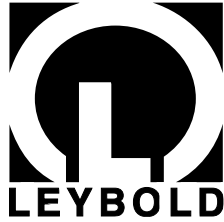

LEYBOLD VACUUM

GA05137_1102

PTB SALES FOR SALES AND SERVICE PLEASE CALL:
PTB SALES T :: 866.332.0500
F :: 626.334.2151
www.ptbsales.com
DATE SERVICED: _____



TURBOVAC TW 250 S

Wide-Range Turbomolecular
Pump with Integrated or External
Frequency Converter

Cat. Nos.

113 52, 114 37,

800150V0007 /09 /11 /12 /13 /14 /16

and pumps modified by
Leybold Vacuum

Operating Instructions

Contents

	Page
Safety information	3
1 Description	5
Use and media compatibility	5
1.1 Design	6
1.2 Standard equipment	6
1.3 Ordering data	8
1.4 Technical data	12
2 Connections	16
2.1 Operating environment	16
2.2 Attach the pump to the vacuum chamber	17
2.3 Forevacuum connection	19
2.4 Cooling the pump	21
2.5 Connect the purge gas and airing valve	22
2.6 Electrical connection	24
2.7 Interface description	29
3 Operation	34
3.1 Switching on	34
3.2 Shutting down	35
3.3 Venting	35
3.4 Bakeout	36
3.5 Removing the pump from the system	37
4 Maintenance	38
4.1 Cleaning	38
4.2 Service by LEYBOLD	38
5 Troubleshooting	39
6 Spare parts	42
EEC Manufacturer's Declaration	43
Index	48

Figures

The references to the diagrams, e.g. (2/10), consist of the figure number and the item number, in that order.

Warning

Identifies working and operating procedures which must be strictly observed to prevent hazards to persons.

Caution

Indicates working and operating procedures which must be strictly observed to prevent damage to or destruction of the appliance.

We reserve the right to alter the design or any data given in these operating instructions.

The illustrations are approximations.

Safety information

Failure to observe the following precautions could result in serious personal injury:

Warning



The turbomolecular pump must only be operated in the proper condition and under the conditions described in the Operating Instructions.

Mechanical hazards

Warning



Never expose any parts of the body to the vacuum.



The high-vacuum flange must be solidly mounted to the vacuum chamber. If the mounting is not sturdy enough, pump blockage could cause the pump to break loose; internal pump components could be thrown in all directions. Never operate the pump (in bench testing, for example) without proper flanging to the vacuum chamber.

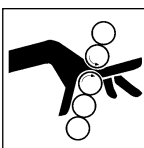

Under vacuum conditions the pump may take up to one hour to run down, when venting to atmospheric pressure it may take up to one minute. During the time the pump is running down, the green LED at the frequency converter will flash, indicating that the rotor has not yet arrived at standstill.



When shutting down by switching off the power supply voltage, there will be only enough power for the LEDs down to a speed of the pump of approximately 200 Hz. Thus the pump may still turn without a LED being on. For this reason, when switching off without venting, wait for approximately 15 minutes after the LEDs have turned off until the pump has arrived at standstill.



After a mains power failure the pump can run up automatically once more.

Electrical hazards

Warning



Mains voltage may be present at the power failure airing valve, the purge gas valve or the venting valve.

The pump may be operated only with a suitable frequency converter and suitable connector cables.

Route all cables so as to protect them from damage.

Do not expose the pump, the frequency converter or the connections to water.

The frequency converter must only be connected to power supplies which meet the requirements for functional extra low voltage with positive isolation in accordance with IEC 364 (VDE 0100, Part 410, or local regulations) (SELV).

When the connector cable is attached, the outputs at the frequency converter are not free of voltage.

Thermal hazards

Warning



During operation the pump can become so hot that there is a danger of burns (up to approx. 80 °C, 176 °F).

Provide protection against contact with the hot components.

Hazards caused by materials and substances

Warning



The forevacuum line must be tight. Hazardous gases can escape at leaks or the gases being pumped can react with air or humidity.



If the pump has previously handled hazardous gases, implement the proper precautionary measures before opening the intake or exhaust connection.



If necessary, use gloves, a respirator and/or protective clothing and work under an exhaust hood.



Failure to observe the following precautions could result in damage to the pump:

Caution

The pumps are **not suitable** for pumping aggressive or corrosive media or those which contain dust.

Install a micropore filter when pumping media which contains dust.

Observe the information on media compatibility at the beginning of these operating instructions.

Caution

Never touch the rotor. Touching the rotor may cause injury and damage the rotor bearing.

Caution

If foreign objects could pass from the vacuum chamber into the pump, install a wire mesh splinter guard. Foreign objects which enter the pump through the intake would cause serious damage to the rotor. Damage resulting from foreign objects in the rotor section are excluded from guarantee coverage.

Caution

Self-protection of the pump is not ensured in case of insufficient cooling.

Caution

Unplug any connectors only when the mains voltage is switched off and the pump does no longer turn (the green LED is off). Separating the connections while the mains power is still applied or while the pump is still turning may destroy the TURBO.DRIVE 300.

Caution

Ensure correct polarity when connecting the frequency converter.

Caution

Exposure of the pump to accelerating forces must be avoided or reduced to such an extent that the rotor unit will not be excited by vibrations. In the case of critical applications you must consult our Applications Dept. first.

Caution

If the pump was exposed to impacts, for example by an earthquake, during start up take note especially of any apparent noises. In the case of any unusual noises coming from the pump, inform Leybold Service.

Caution

Pumps with integrated frequency converter need to be shipped to the Leybold Service with the frequency converter. Pump and frequency converter must not be separated.

Caution

The pump must only be opened by such persons who have been authorised by Leybold to do so.

1 Description

Use and media compatibility

The TURBOVAC TW 250 S is a turbomolecular pump with integrated or external frequency converter. It is designed to evacuate vacuum chambers down to pressure levels in the high vacuum range. It is suitable for pumping air and clean, non-corrosive gases. A forevacuum pump is required for its operation.

The TW 250 S has been manufactured according to the state-of-the-art and approved safety regulations. Even so in the case of improper installation or when improperly used there can be risks or damage may be caused.

These pumps are **not** suitable for

- pumping liquids or gases containing dust or particulates
- pumping aggressive, explosive or reactive gasses
- operation without a forevacuum pump.

If reactive gases in low concentrations must be pumped please consult with Leybold.

During operation the pressure inside the pump is so low that there is no danger of ignition (at pressures below about 100 mbar). A hazardous condition will be created if flammable mixtures enter the hot pump at pressures above 100 mbar. During operation the pump can reach temperatures as high as 110°C (230 °F). Ignition sparks could occur in case of damage to the pump and these could ignite explosive mixtures.

All seals are prone to leaks. In case a seal fails, there is the risk that hazardous gases may escape. Introduce the appropriate safety measures depending on the media being pumped in each case.

We would be glad to consult with you as regards the media which can safely be handled with this unit.

Warning



Never expose any parts of the body to the vacuum.

1.1 Design

The pumps comprise essentially the pump housing, a multi-stage rotor with the stator group, and the drive.

The rotor consists of a turbomolecular pump stage and a Holweck stage. The Holweck pumping stage increases the permissible forevacuum pressure level markedly when compared with the classical turbomolecular pump.

The rotor shaft runs in two ceramic ball bearings, lubricated with grease.

The pump is driven by a brushless DC split-cage motor. In this motor the rotor and stator windings are separated by a vacuum-tight can. Consequently the rotor runs inside the vacuum while the stator is outside the vacuum. This eliminates any need of vacuum feedthroughs.

A circuit board and a fan are installed in the pump. The circuit board is equipped with a temperature sensor and a resistor code.

Water cooling is available as optional equipment; this is bolted to the housing of the pump.

KF type components can be connected directly to the forevacuum flange using a clamping yoke.

The pumps exhibit a threaded hole, used as the connection point for venting. This port is sealed at the factory with a screw and gasket ring.

The TURBOVAC TW 250 S has an additional purge gas device. The purge gas is also connected at the venting port.

The pump is driven by an electronic frequency converter TURBO.DRIVE S. All functions like, for example, speed control, pump sensing or temperature monitoring are monitored by the TURBO.DRIVE S. This unit is powered by an external power supply.

1.2 Standard equipment

The pumps are shipped sealed in a PE bag with a desiccant to absorb moisture. The maximum useful life of the desiccant is one year.

The forevacuum flange is blank-flanged with centering ring with FPM sealing ring and a clamping yoke. The venting port is sealed with a screw and a gasket ring.

The high-vacuum connections elements are **not** part of the standard equipment.

A suitable DC coupling for the power supply is included: In the case of pumps with integrated frequency converter it is supplied with the pump.; in the case of pumps with a separate frequency converter it is supplied with the frequency converter.

PE = Polyethylene

FPM = Fluororubber, resistant to temperatures up to 150°C (302 °F)

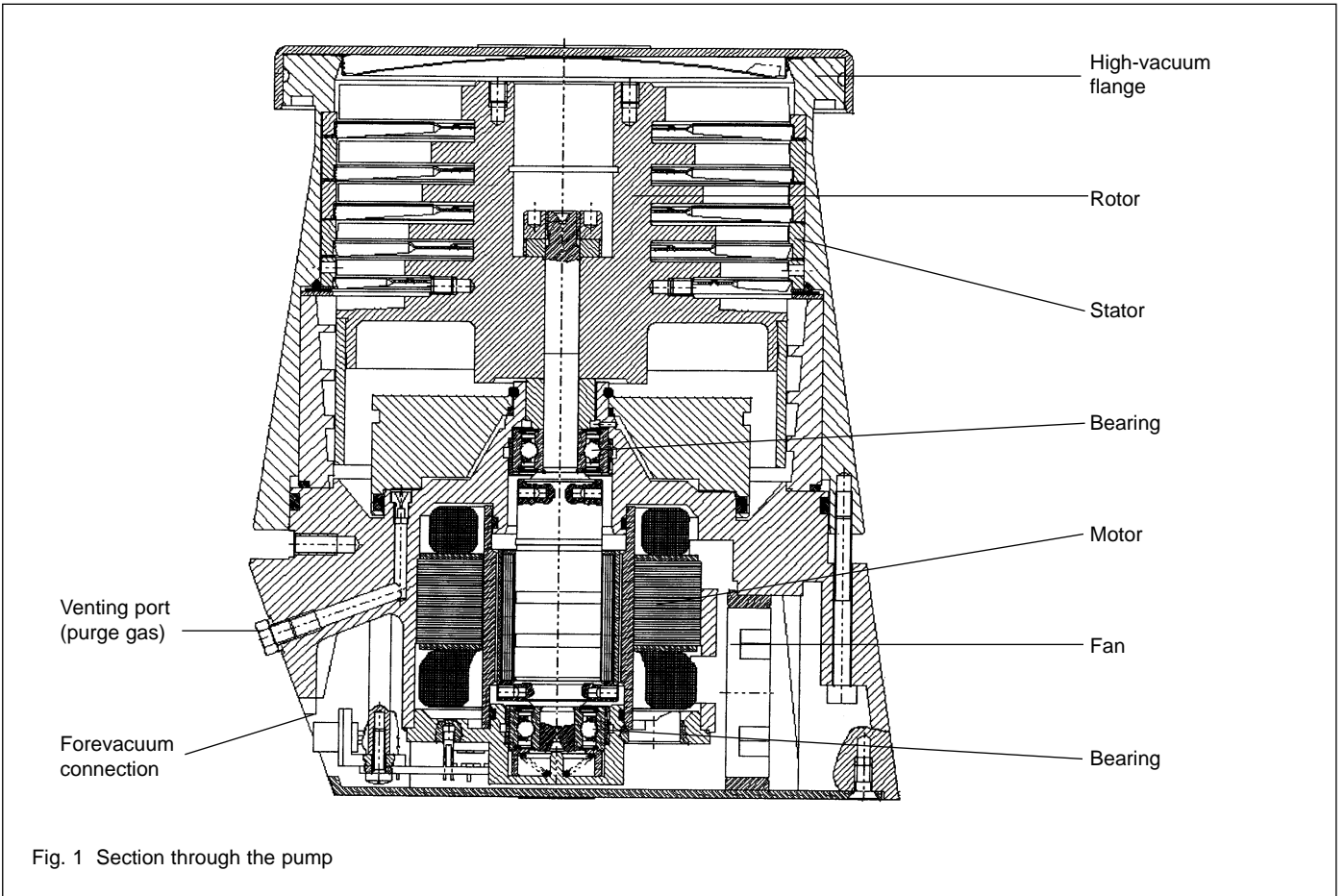

1.3 Ordering data

1.3.1 Pumps

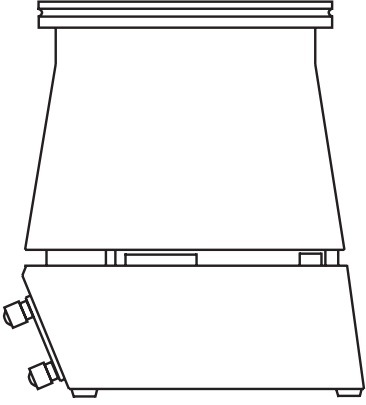
TURBOVAC TW 250 S DN 100 ISO-K, air cooling, without frequency converter, with coarse splinter guard	113 52	
DN 100 ISO-K, water cooling, with TURBO.DRIVE S with Profibus, without splinter guard	114 37	
DN 100 ISO-K, air cooling, without frequency converter, with coarse splinter guard	800150V0007	
DN 100 ISO-K, air cooling, with TURBO.DRIVE S with Profibus, with coarse splinter guard	800150V0009	
DN 100 ISO-K, air cooling, with TURBO.DRIVE S with RS 232, without splinter guard	800150V0011	
DN 100 CF, air cooling, with TURBO.DRIVE S with RS 232, without splinter guard	800150V0012	
DN 100 ISO-K, air cooling, with TURBO.DRIVE S with RS 485, without splinter guard	800150V0013	
DN 100 CF, air cooling, with TURBO.DRIVE S with RS 485, without splinter guard	800150V0014	
DN 100 ISO-K, water cooling, with TURBO.DRIVE S with Profibus, with coarse splinter guard	800150V0016	

1.3.2 Frequency converter and accessories for the frequency converter

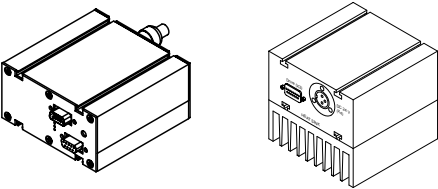
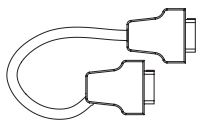

Frequency converter (only for pumps without frequency converter)

Frequency converter TURBO.DRIVE S with RS 232 interface	800070V0002	
with RS 232 interface and mounted heat sink	800070V0005	
with RS 485 interface	800070V0003	
with RS 485 interface and mounted heat sink	800070V0006	
with Profibus interface	800070V0004	
Connecting cable pump - frequency converter 1.0 m long	152 47	
2.5 m long	864 49	
3.0 m long	864 40	
5.0 m long	864 50	

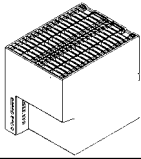
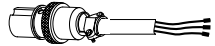
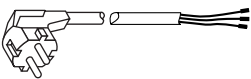
OEM power supply (with screw terminals)

Power supply SITOP 24 V / 10 A • supplies the TURBO.DRIVE S with 24 V DC	152 50	
24 V DC cable (TURBO.DRIVE S – OEM power supply) 3 m	200 12 732	
5 m	200 12 733	
10 m	200 12 734	
20 m	200 12 735	
Mains cable for power supply, 2 m long with EURO plug / conductor ferrules	800102V0001	
with US plug 5-15P / conductor ferrules	800102V1001	

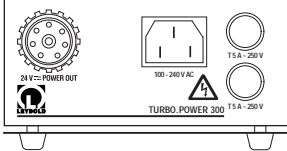
Power supply unit - plug and play

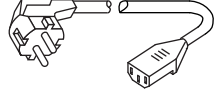
<p>TURBO.POWER 300</p> <ul style="list-style-type: none"> • supplies the TURBO.DRIVE S with 24 V DC • plug & play cables • desktop unit or rack mountable 	<p>800100V0002</p>	
<p>24V DC Power cable (TURBO.DRIVE S – TURBO.POWER 300)</p> <p>1 m 3 m 5 m 10 m 20 m</p>	<p>800094V0100 800094V0300 800094V0500 800094V1000 800094V2000</p>	
<p>Mains cable for TURBO.POWER 300, 3 m long with EURO plug / IEC mains plug with US plug 6-15P / IEC mains plug</p>	<p>800102V0002 800102V1002</p>	

Power supply and control unit

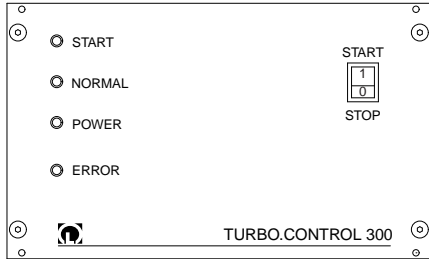
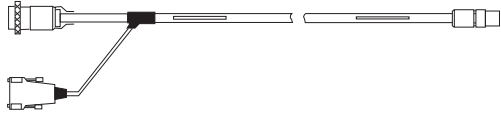
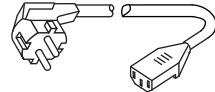
<p>TURBO.CONTROL 300</p> <ul style="list-style-type: none"> • supplies the TURBO.DRIVE S with 24 V DC • plug & play cables • desktop unit or rack mountable • with power switch • with start/stop switch for the turbomolecular pump • remote control • status LEDs and status relays 	<p>800100V0001</p>	
<p>24V DC Control cable (TURBO.DRIVE S – TURBO.CONTROL 300)</p> <p>1 m 3 m 5 m 10 m 20 m</p>	<p>800091V0100 800091V0300 800091V0500 800091V1000 800091V2000</p>	
<p>Mains cable for TURBO.CONTROL 300, 3 m long with EURO plug / IEC mains plug with US plug 6-15P / IEC mains plug</p>	<p>800102V0002 800102V1002</p>	

Description



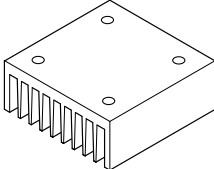
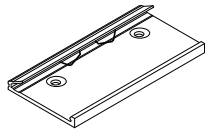

Mechanical accessories

Plug for connector REMOTE with integrated ON/OFF switch for the pump (Sub-D plug, 9 way)	152 48	
Heat sink for frequency converter	800110V0001	
Top hat rail adaptor (mounting aid for TURBO.DRIVE S and TURBO.POWER 300)	800110V0003	

Accessories for serial interfaces

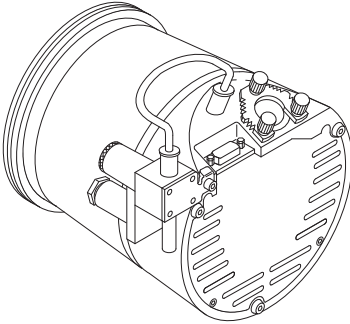
Display PDA* (display unit for parameters, requires the software "Turbo.Drive Panel") data cable and adaptor	upon request	
Required "Turbo.Drive Panel" software for the display PDA with operating system OS 4.0 to 4.x, 3.5" floppy	800110V0104	
PC software "Turbo.Drive Server" for Windows 95 and higher, CD-ROM* <ul style="list-style-type: none"> • Soft panel • Display, change, save and compare parameter lists • Integration of customer's software • Record parameter data 	800110V0102	
Adaptor RS232/RS485 for 220 V/Euro plug	800110V0101	
GSD file for Profibus DP	upon request	
* Can be used in connection with the following interfaces: <ul style="list-style-type: none"> - For frequency converters with RS232 interface. - For frequency converters with RS485 interface, a RS232/RS485 adaptor is required. 		

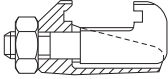
1.3.3 Accessories for the pump

Splinter guard coarse Splinter guard fine	800132V0101 800132V0102	
Vibration absorber DN 100 ISO-K DN 100 CF	800131V0100 500 071	
Water cooling unit with G 1/8" connection Adaptor G 1/8" — 1/4" Swagelok	200 06 255 200 12 686	
Power failure airing valve, 220/240 V AC Power failure airing valve, 24 V AC Venting valve, 220/240 V AC Venting valve, 110/120 V AC Venting valve, 24 V AC Venting valve, 24 V DC Mounting kit for power failure airing valve or venting valve	280 71 280 85 280 70 280 72 280 73 280 74 863 20	
Flange heater DN 100 CF (only for pumps with CF flange) 230 V 110 V	854 27 854 28	
Centering ring (Al) with O-ring (FPM) DN 100 ISO-K	268 42	
Clamps (Set of 4 pieces) Galvanized steel, clamping range 19 to 27 mm Galvanized steel clamping range 25 to 35 mm Stainless steel, clamping range 19 to 27 mm	267 01 267 02 887 99	
Copper gasket rings for CF flange (Set of 10 pieces)	839 45	
Set of hex. screws with nuts, screws and washers for CF flange	839 04	

1.4 Technical data

1.4.1 TURBOVAC

High-vacuum connection	DN 100 ISO-K DN 100 CF
Pumping speed at 10 ⁻⁵ mbar	
N ₂	230 l·s ⁻¹
Ar	210 l·s ⁻¹
H ₂	80 l·s ⁻¹
He	150 l·s ⁻¹
Max. gas throughput	
N ₂	3.7 mbar·l·s ⁻¹ at 10 ⁻¹ mbar
Ar	1.6 mbar·l·s ⁻¹ at 10 ⁻² mbar
H ₂	1.1 mbar·l·s ⁻¹ at 10 ⁻¹ mbar
He	2.4 mbar·l·s ⁻¹ at 10 ⁻¹ mbar
Compression	
N ₂	3.0·10 ⁷ at 3 mbar
Ar	1.0·10 ⁷ at 6 mbar
H ₂	5.0·10 ² at 0.2 mbar
He	3.2·10 ³ at 0.7 mbar
Ultimate pressure with two-stage, oil-sealed rotary vane pump	< 2·10 ⁻⁸ mbar
Max. permissible forevacuum pressure for N ₂	3 mbar
Recommended forevacuum pumps	
• TRIVAC	D 2,5 E
• ECODRY	M 15
• Diaphragm pump with ultimate pressure < 3 mbar and pumping speed at 3 mbar	upon request > 2 m ³ ·h ⁻¹
• (at purge gas operation) TRIVAC	D 8 B
Operating speed	51,600 rpm
Run-up time	approx. 3 min
Forevacuum connection	DN 16 KF
Venting connection	thread M 5
Weight	
without frequency converter	5.0 kg
with frequency converter	5.8 kg
Noise level	< 55 dB(A)
Type of protection	IP 20
Option pump with water cooling	
Cooling water connections	G 1/8"
Cooling water data	see Section 2.4

1.4.2 TURBO.DRIVE S

Supply voltage	24 V \pm 5%
Residual ripple	< 2%
When operating a TW 250 S	
Max. power consumption	140 W
Max. peak current, input side	6 A \pm
Required power output from the power supply	\geq 150 W
Max. length of the DC cable (shielded)	
at 3 x 1.5 mm ²	5 m
at 3 x 2.5 mm ²	20 m
Load capability, relay output	42 V, 0.5 A
Ambient temperature	
during operation	10 - 45 °C
storage	- 15 - + 70 °C
Temp. of the cooling surface	10 - 55 °C
Only Part No. 800070V0004	10 - 50 °C
Power loss	\leq 20 W
Relative air humidity	5 to 85 % non-condensing
Type of protection	IP 20
Weight, approx.	0.7 kg

1.4.3 Power supply SITOP 24 V / 10 A

AC input voltage	120/230 V, 50/60 Hz
Tolerance	93 - 132 V 187 - 264 V
Recommended circuit breaker (characteristic C)	16 A
Power consumption	270 W
DC output voltage	24 V \pm 1%
DC output current	0 - 10 A
Weight, approx.	1 kg
Mounting	DIN rail
Screw-type terminals	0.5 - 2.5 mm ² 22 - 12 AWG
Ambient temperature	
during operation	0 - 60 °C
storage	-25 - + 85 °C
Cooling	air convection
Type of protection	IP 20
Safety to EN60950	SELV
RI suppression to EN 55022	limit curve B
Noise immunity to EN 50082-2	incl. Table A4
UL508 FILE	E143289
Technical data for TURBO.POWER 300 and TURBO.CON- TROL 300 see instructions for the power supplies	

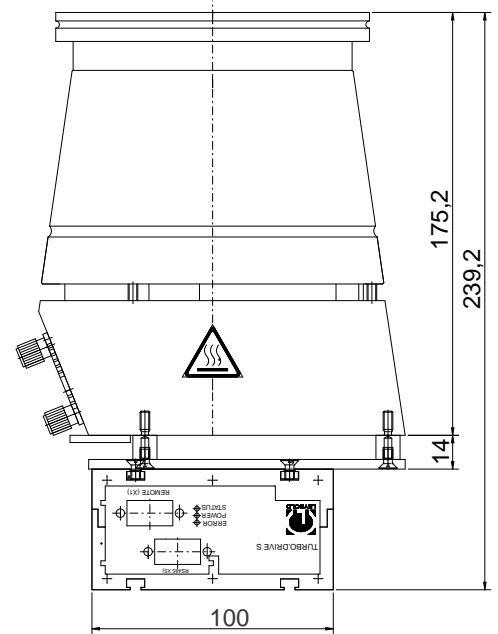
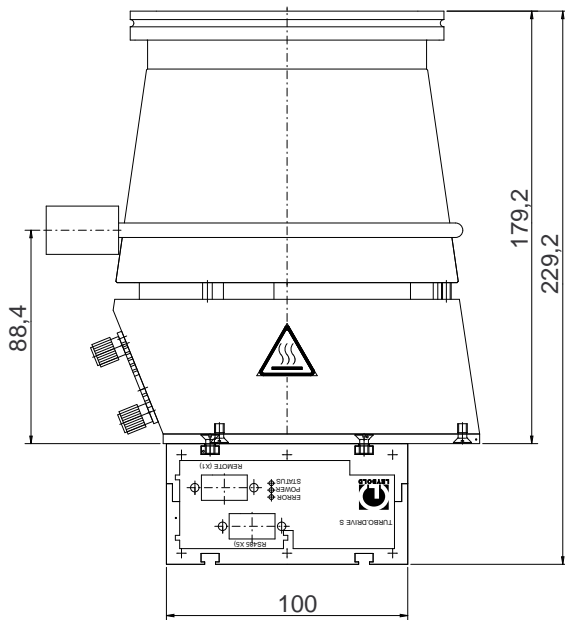
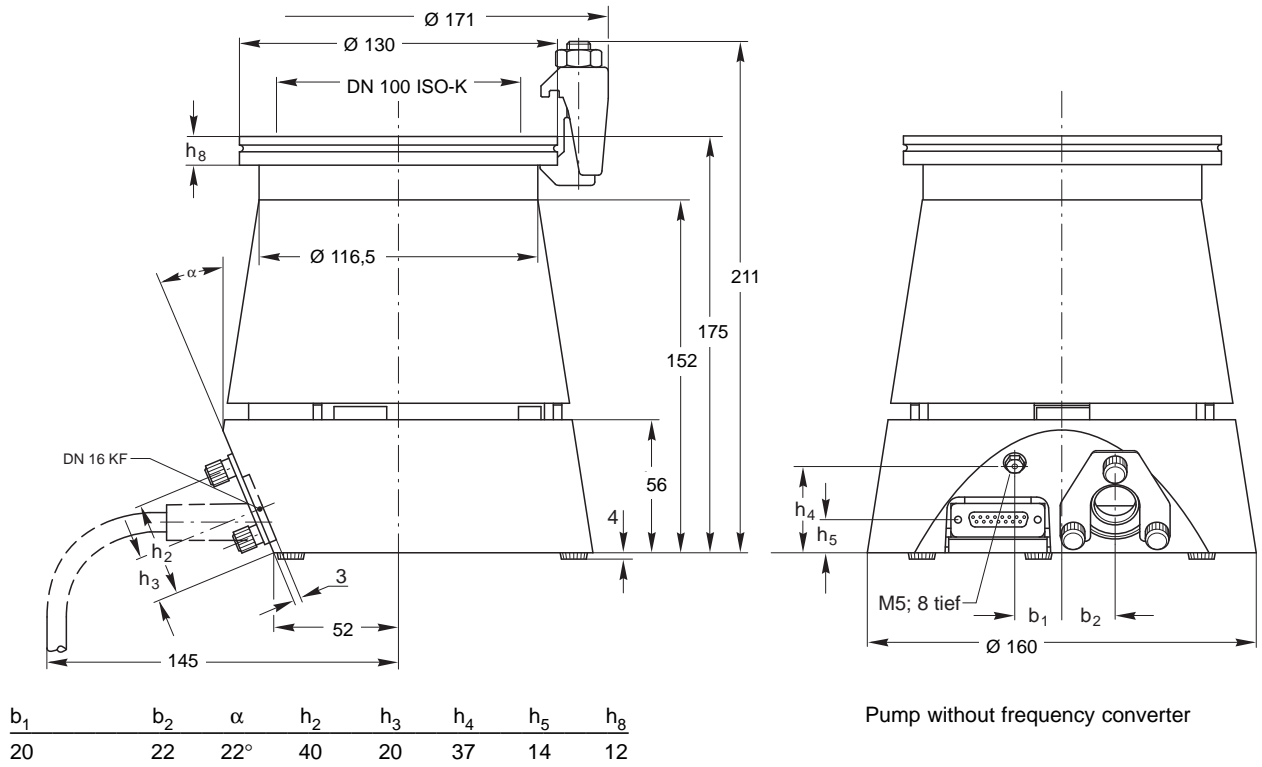

Fig. 2 Dimensional drawing for the pump, dimensions in mm

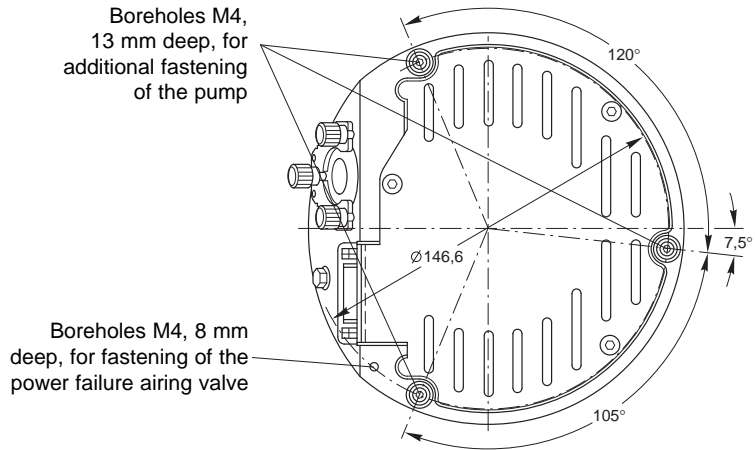

Fig. 3 Bottom of the pump, dimensions in mm

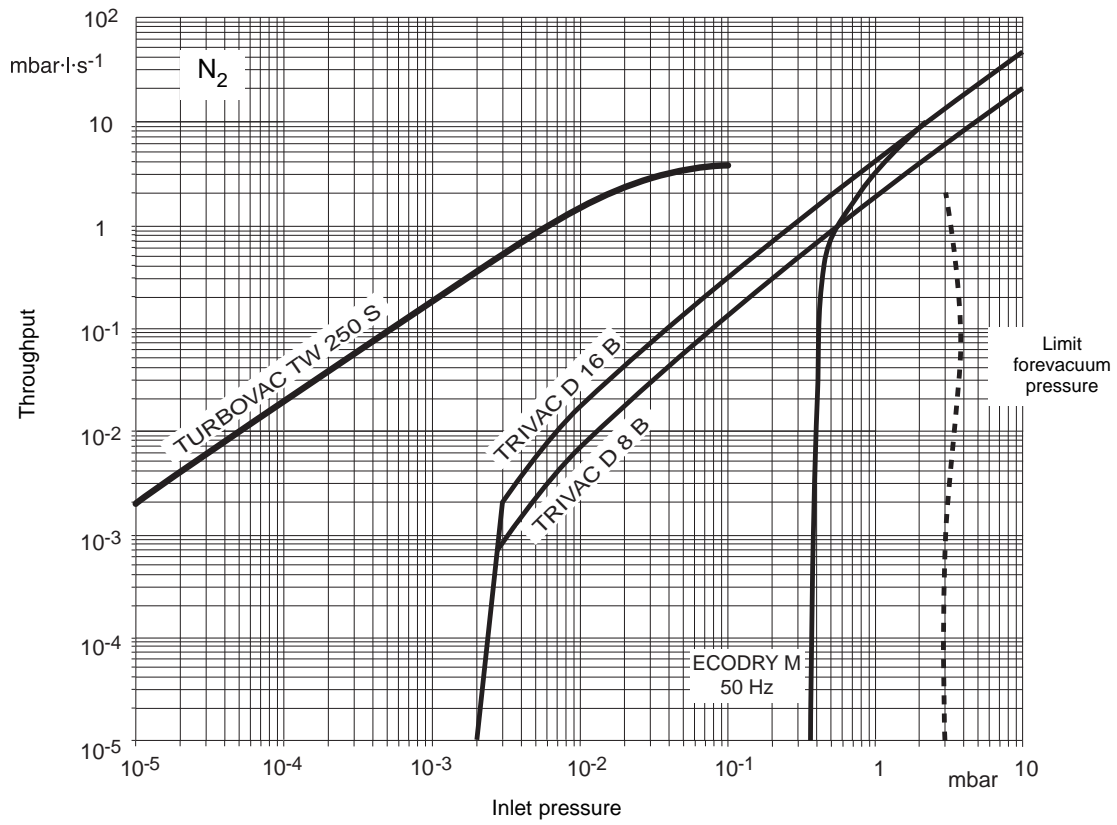
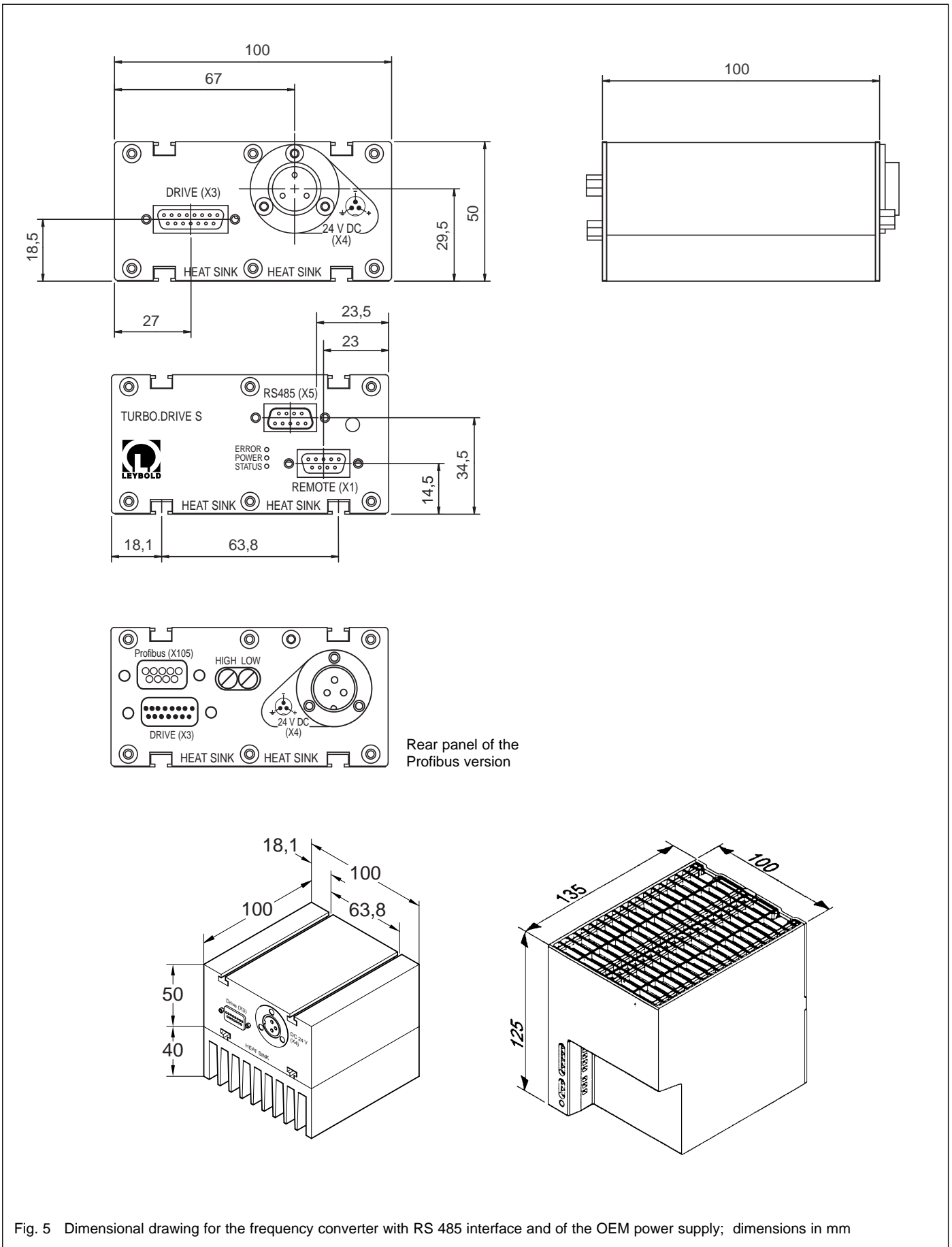

Fig. 4 Operation diagram for nitrogen



2 Connections

Caution

The pumps are **not suitable** for pumping aggressive or corrosive media or those which contain dust.

Install a micropore filter when pumping media which contains dust.

Observe the information on media compatibility at the beginning of these operating instructions.

Do not open the packaging until immediately before installation.

Do not remove the covers and blind flanges on the pump until just before attachment to the equipment to ensure that assembly is carried out under the cleanest possible conditions.

Caution

Never touch the rotor. Touching the rotor may cause injury and damage the rotor bearing.

Warning



During operation the pump can become so hot that there is a danger of burns (up to approx. 80 °C, 176 °F).

Provide protection against contact with the hot components.

2.1 Operating environment

The maximum permissible ambient temperature of the pump is 40 °C (104 °F). Do not expose the pump or the frequency converter to dripping or spraying water

If the pump is used within a magnetic field, the magnetic induction at the surface of the pump housing may not exceed:

B = 5 mT if impinging radially and

B = 15 mT if impinging axially.

Install shielding equipment as appropriate if these values are exceeded.

The standard pump version without frequency converter is resistant to radiation up to 10³ Gy.

Places of installation up to 1000 m above sea level (3300 ft) are possible without restrictions. At altitudes over 1000 m heat dissipation by the ambient air is impaired. Please consult us.

The frequency converter must not be operated in explosive gas atmospheres.

1 mT (milliTesla) = 10 G (Gauß)

1 Gy (Gray) = 100 rad

Legend for Fig. 6

- 1 High-vacuum connector flange
- 2 Wire mesh splinter guard
- 3 Forevacuum connection
- 4 Venting port (purge gas), M5
- 5 Connection for frequency converter

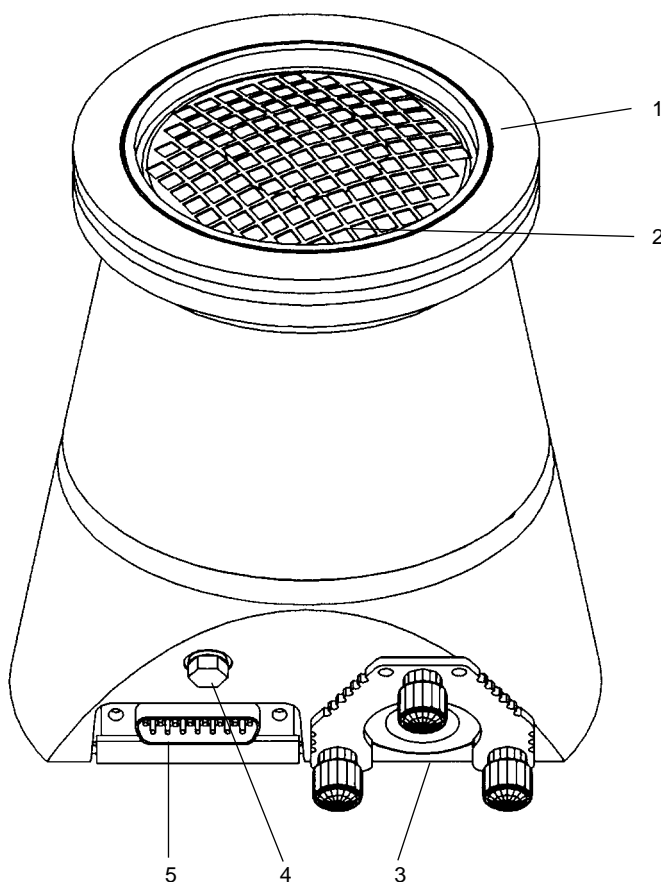

Fig. 6 Connection elements

2.2 Attach the pump to the vacuum chamber

Warning



The high-vacuum flange must be solidly mounted to the vacuum chamber. If the mounting is not sturdy enough, pump blockage could cause the pump to break loose; internal pump components could be thrown in all directions. Never operate the pump (in bench testing, for example) without proper flanging to the vacuum chamber.

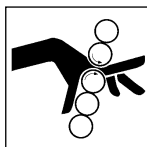

If the pump should suddenly seize, an ensuing deceleration torque of up to 200 Nm will have to be absorbed by the system. To accomplish this, a minimum of 4 clamping bolts are required for securing an ISO-K type high-vacuum flange.

Clamping bolts must be torqued down to 20 Nm (15 ft-lb).

In most applications the pump is flanged to the high-vacuum flange at the apparatus. The pump can be mounted and operated in any desired attitude. No support is required.

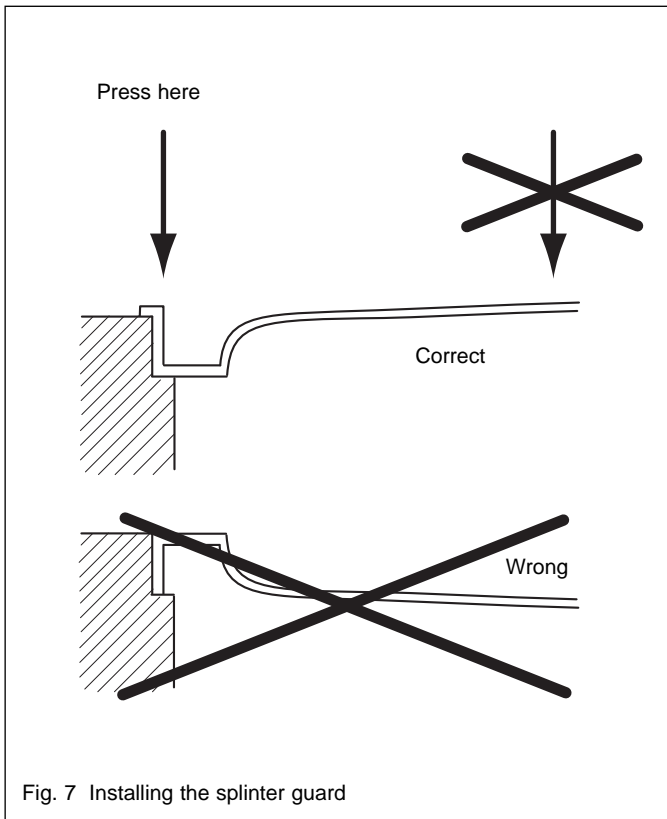

Fig. 7 Installing the splinter guard

Caution

If foreign objects could pass from the vacuum chamber into the pump, install a wire mesh splinter guard. Foreign objects which enter the pump through the intake would cause serious damage to the rotor. Damage resulting from foreign objects in the rotor section are excluded from guarantee coverage.

Insert the splinter guard so that the surface curvature is at the top and apply some pressure lightly at the rim so that the splinter guard engages. The splinter guard **must not touch the rotor**.

If dust could pass from the vacuum chamber into the pump, then a micropore filter must be installed between the vacuum chamber and the pump.

The pump is precision balanced and is generally operated without a resonance damper. To decouple extremely sensitive equipment and to prevent transfer of external vibrations to the pump a special resonance damper is available for mounting at the high-vacuum flange.

Detach the shipping flange from the high-vacuum flange and remove the desiccant. Pay attention to scrupulous cleanliness when making the connection.

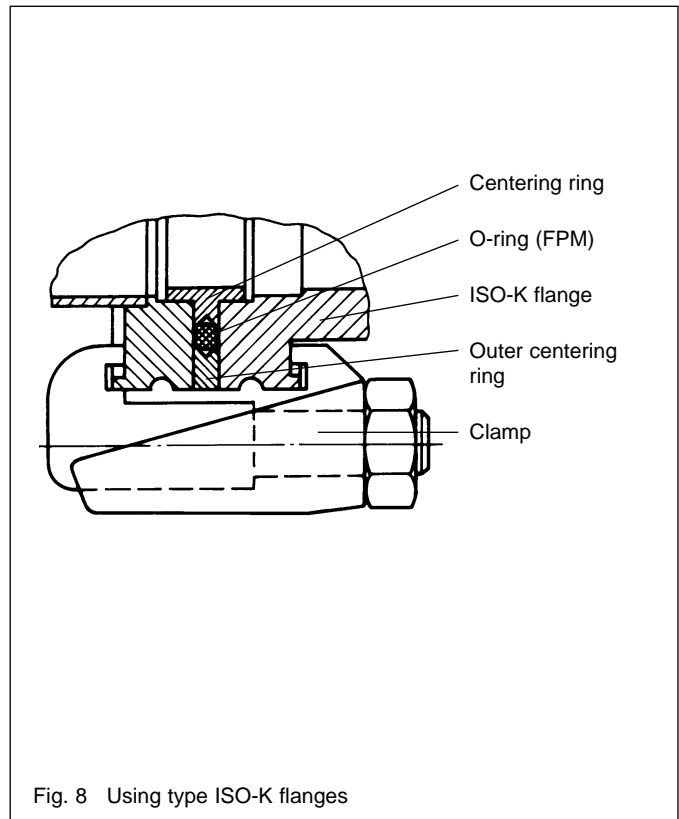

Fig. 8 Using type ISO-K flanges

Design with ISO-K clamp flange

Lay the O-ring on the centering ring.

The O-ring must be positioned so as to be smooth and flat; it must not be twisted. Then position the outer ring.

A collar flange with circlip and the appropriate gasket may be used to connect the pump.

A collar flange is required when using ultra-vacuum sealing gaskets.

The order numbers for the flange components are given in the Leybold Catalog.

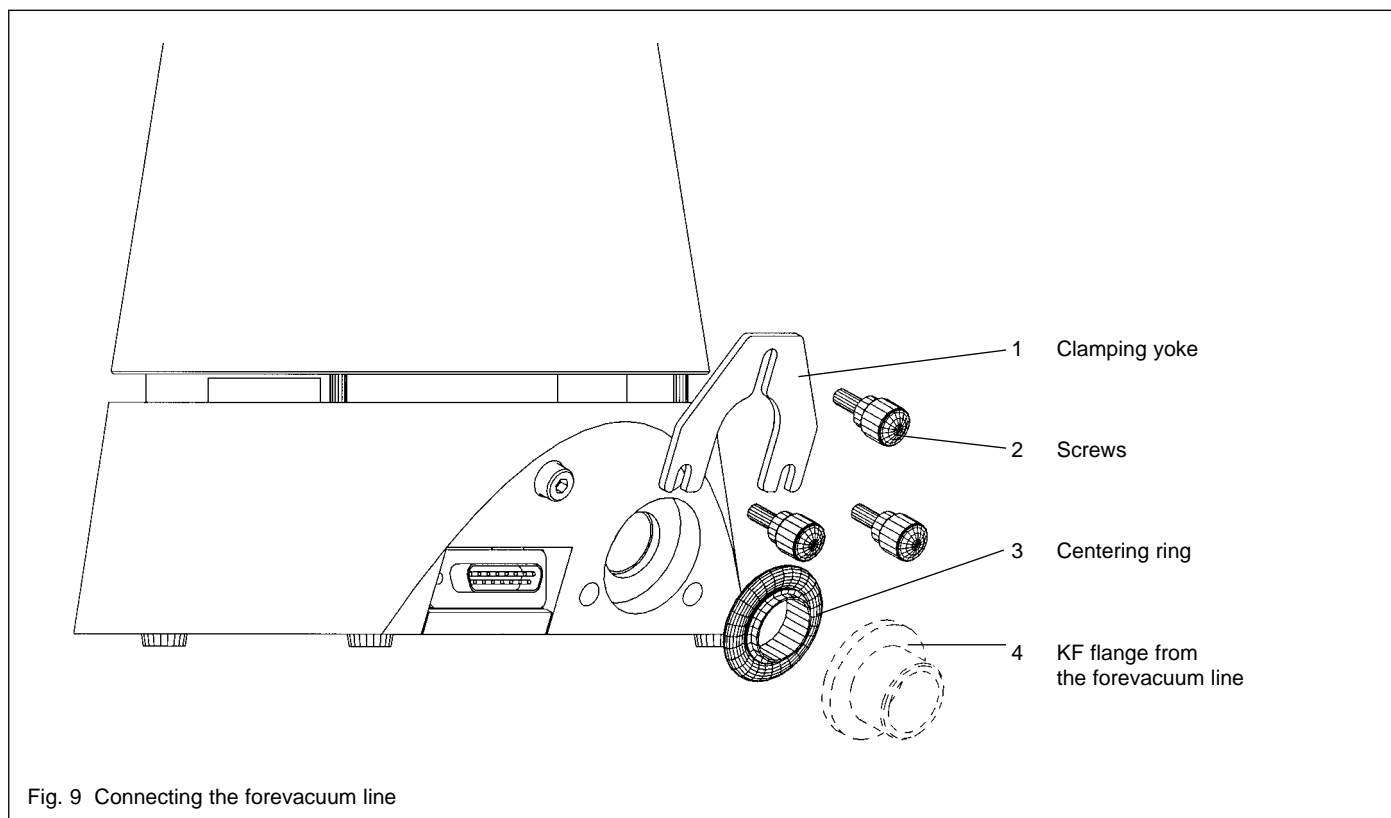

2.3 Forevacuum connection

As forevacuum pump we recommend using the dry compressing ECODRY M15 piston pump or a TRIVAC two-stage rotary vane vacuum pump, e.g. the D 2,5 E.

Connect the clean forevacuum line; see Fig. 9. The connecting flanges must be clean and undamaged. The cross section of this line must be so wide that safe operation of the pump can be ensured.

Remove the three screws and the clamping yoke. Remove the shipping flange.

Slide the KF flange from the forevacuum line onto the centering ring, slide the clamping yoke over the flange, insert and tighten the three screws.

Warning



The forevacuum line must be tight. Hazardous gases can escape at leaks or the gases being pumped can react with air or humidity.

Figure 14 is a schematic diagram of a pump system incorporating a turbomolecular pump and a TRIVAC forevacuum pump with an anti-suckback valve.

A separate safety valve is provided for oil-sealed forevacuum pumps without an anti-suckback valve. The safety valve prevents oil flowing back from the forevacuum pump into the turbomolecular pump when the system is not running.

To ensure that the forevacuum space at the turbomolecular pump is kept largely free of oil vapors during operation, as well, we recommend installing an adsorption trap in the forevacuum line. An adsorption trap is not required when using a dry compressing forevacuum pump like the ECODRY M 15, for example.

Provide a roughing line to achieve the shortest cycle times.

Ensure that the pump is sufficiently isolated against resonances (vibrations) generated by the forevacuum pump.

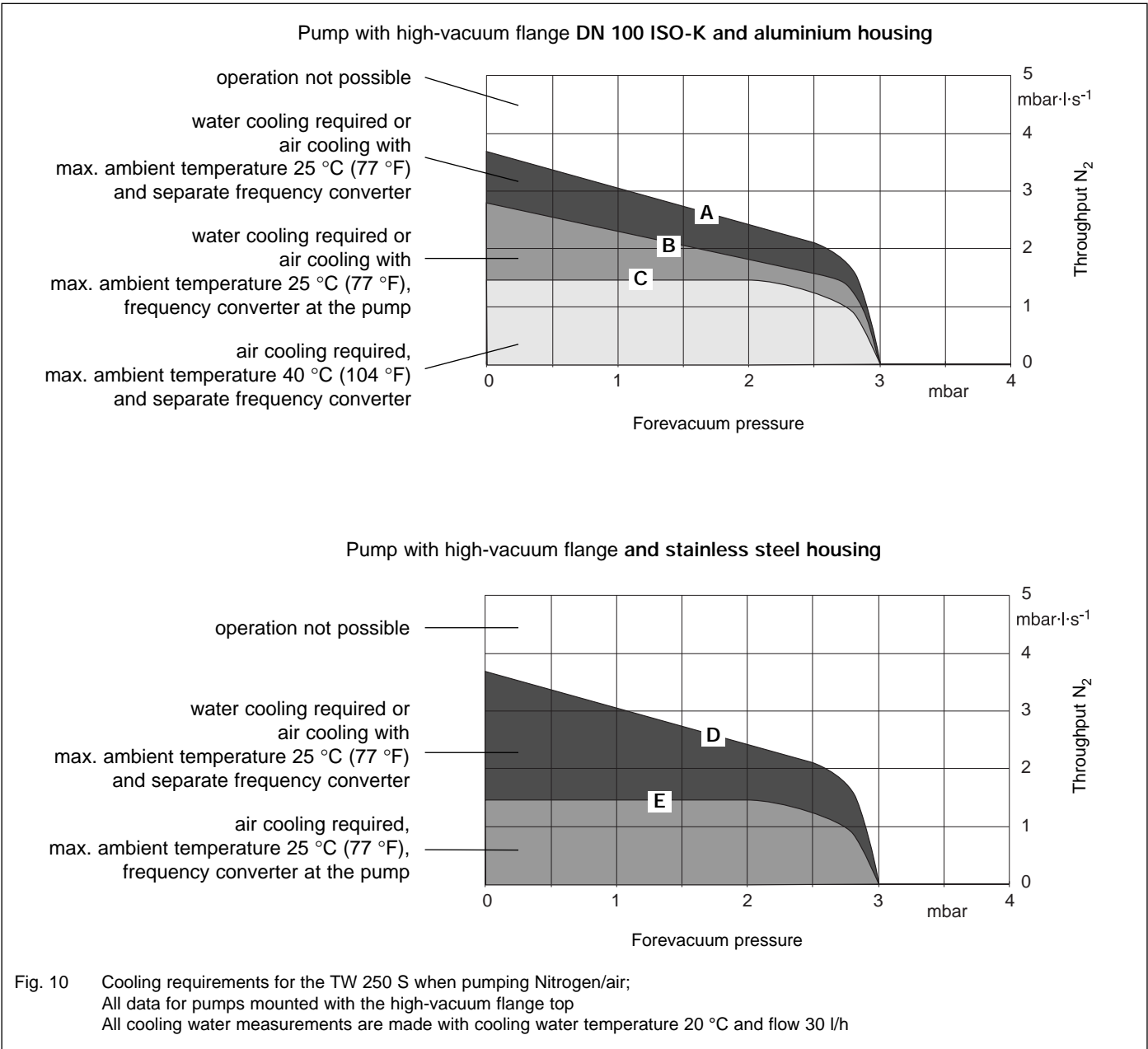

Ambient temperature	Frequency converter at the pump		Separate frequency converter	
	DN 100 ISO-K	DN 100 CF	DN 100 ISO-K	DN 100 CF
> 40 °C (104 °F)	Operation not possible			
≤ 40 °C (104 °F)	Operation only after consultation with Leybold (Water cooling required, curve B)	Operation not possible	air cooling possible curve C	Water cooling required curve D
≤ 25 °C (77 °F)	air cooling possible curve B	air cooling possible curve E	air cooling possible curve A	air cooling possible curve D

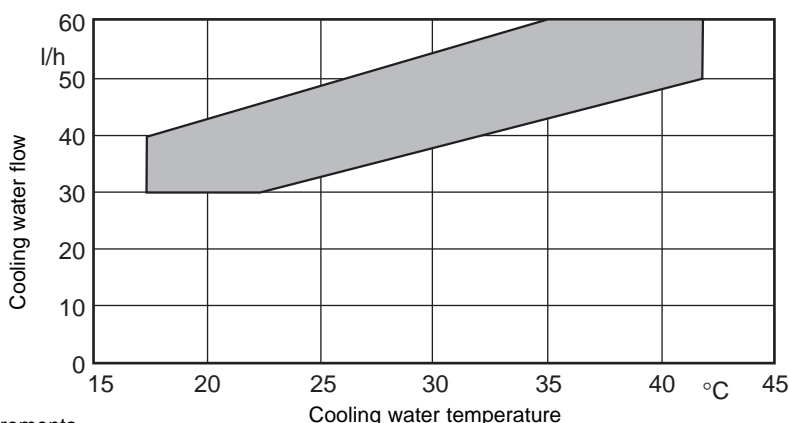

Fig. 11 Cooling water requirements

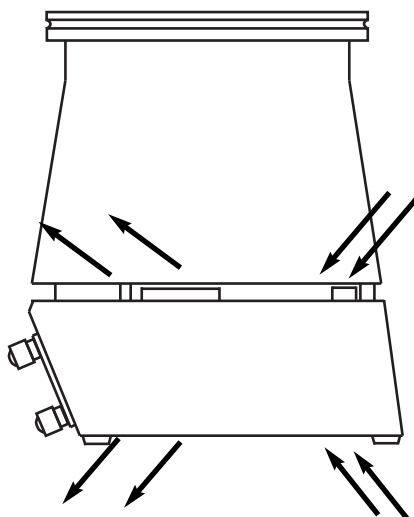

Fig. 12 Cooling air flow pattern

2.4 Cooling the pump

The cooling for the TW 250 S depends on the required pump performance and the ambient temperature; see Fig. 10.

Caution

Self-protection of the pump is not ensured in case of insufficient cooling.

High gas throughputs, cyclic operation or high ambient temperatures will necessitate water cooling.

Air cooling

The pump is equipped with an internal fan which is fed by the DC supply of the frequency converter. When installing the pump into a housing, ensure that the flow of cooling air is not restricted.

Cooling water specifications

Feed temperature	20 - 40 °C
Feed pressure	3 to 7 bar absolute
Cooling water requirement	See Fig. 11
Appearance	colourless, clear, free of oils and greases
Sediments	< 250 mg/l
Particle size	< 150 µm
pH value	7 to 8.5
Overall hardness (total alkaline earths)	max. 20 ° German hardness scale (= 3.57 mmol/l)

Further information on request.

Connecting the cooling water

Screw on the cooling water lines.

When switching the cooling water supply on and off by means of an electrically actuated valve, connect the valve so that it will be switched on and off together with the pump.

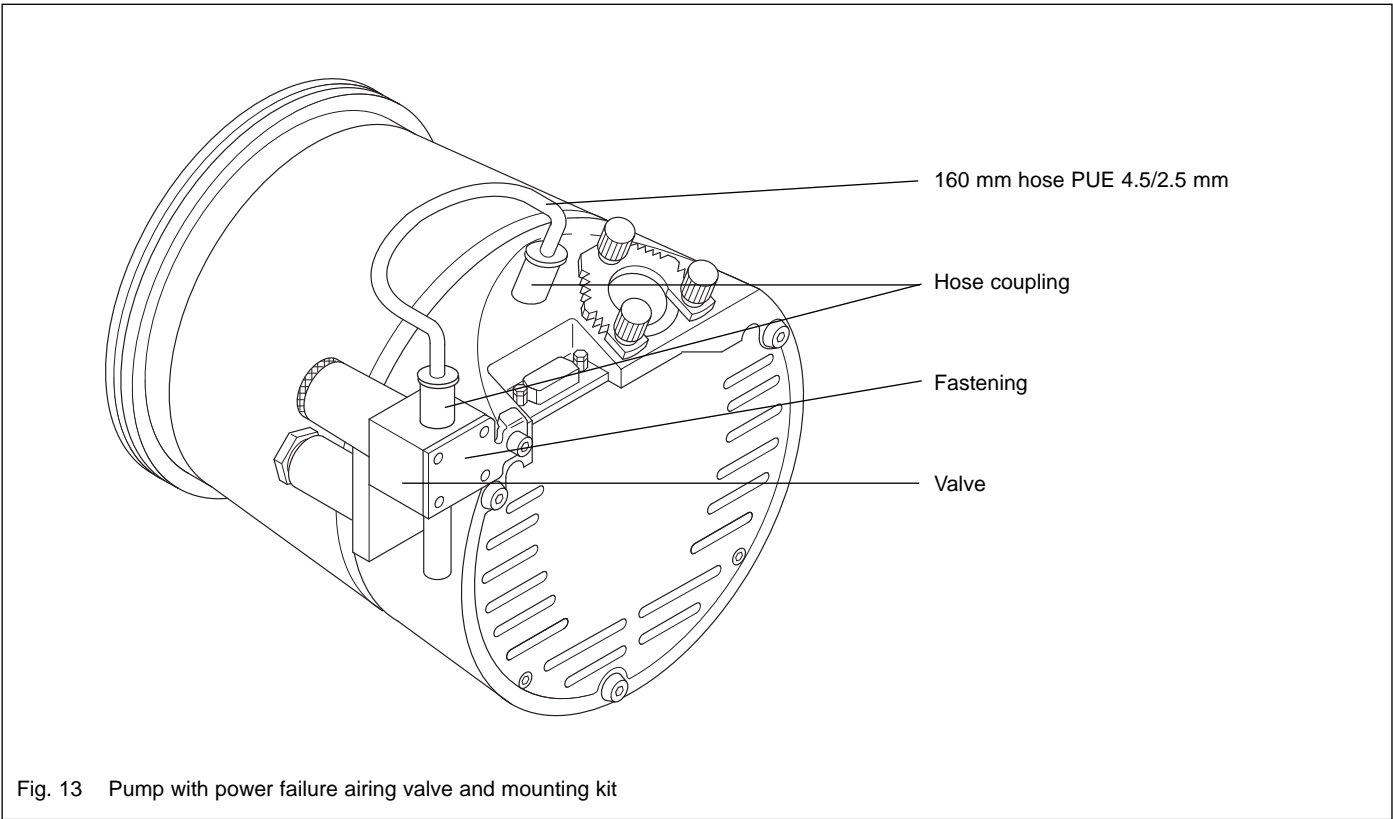

Fig. 13 Pump with power failure airing valve and mounting kit

2.5 Connect the purge gas and airing valve

The pumps have a threaded port (Fig. 6 / Item 4) which serves as the vent connection; it is sealed with a screw and gasket during shipment.

This port is provided for connecting a power failure airing valve or a venting valve.

For the connection of the power failure airing valve or venting valve we recommend the mounting kit.

Warning



Mains voltage may be present at the power failure airing valve or the venting valve.

The power failure airing valve or venting valve vents the pump and the forevacuum line when the pump is switched off and thus keeps oil vapor from diffusing back from the forevacuum line.

A choke nozzle in the vent port ensures that the pump is not vented too fast.

When pumping **abrasive** media, connect a purge gas and venting valve, so as to protect the bearings against light contamination.

Please contact Leybold for assistance in making the decision as to which media can be pumped with or without purge gas.

In processes which require purge gas the pump will have to be vented, when it is switched off, through the purge gas valve.

Suited are all gases,

- which will not cause corrosion or pitting in aluminium and steel and
- which in connection with process deposits in the pump will not cause corrosion or sticking.

For venting and as the purge gas we recommend inert gases like nitrogen or argon. The temperature of these gases should be between 5 °C and 80 °C , max. relative humidity should not exceed 10 ppm.

In individual cases and after consultation also dry, filtered, oil-free air or filtered ambient air may be used (filter mesh < 1µm).

Change the filters after some time, at least annually.

Different venting methods are described in Chapter 3.3.

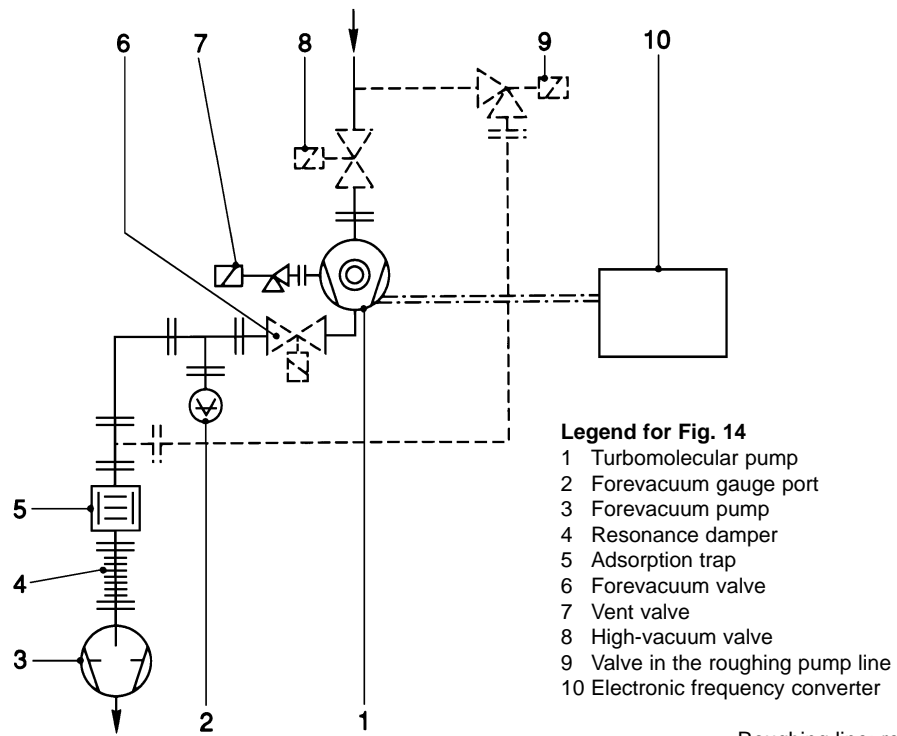

Legend for Fig. 14

- 1 Turbomolecular pump
- 2 Forevacuum gauge port
- 3 Forevacuum pump
- 4 Resonance damper
- 5 Adsorption trap
- 6 Forevacuum valve
- 7 Vent valve
- 8 High-vacuum valve
- 9 Valve in the roughing pump line
- 10 Electronic frequency converter

— — — — — Roughing line; recommend to achieve the shortest possible cycle times

Fig.14 Schematic of a turbomolecular pump system

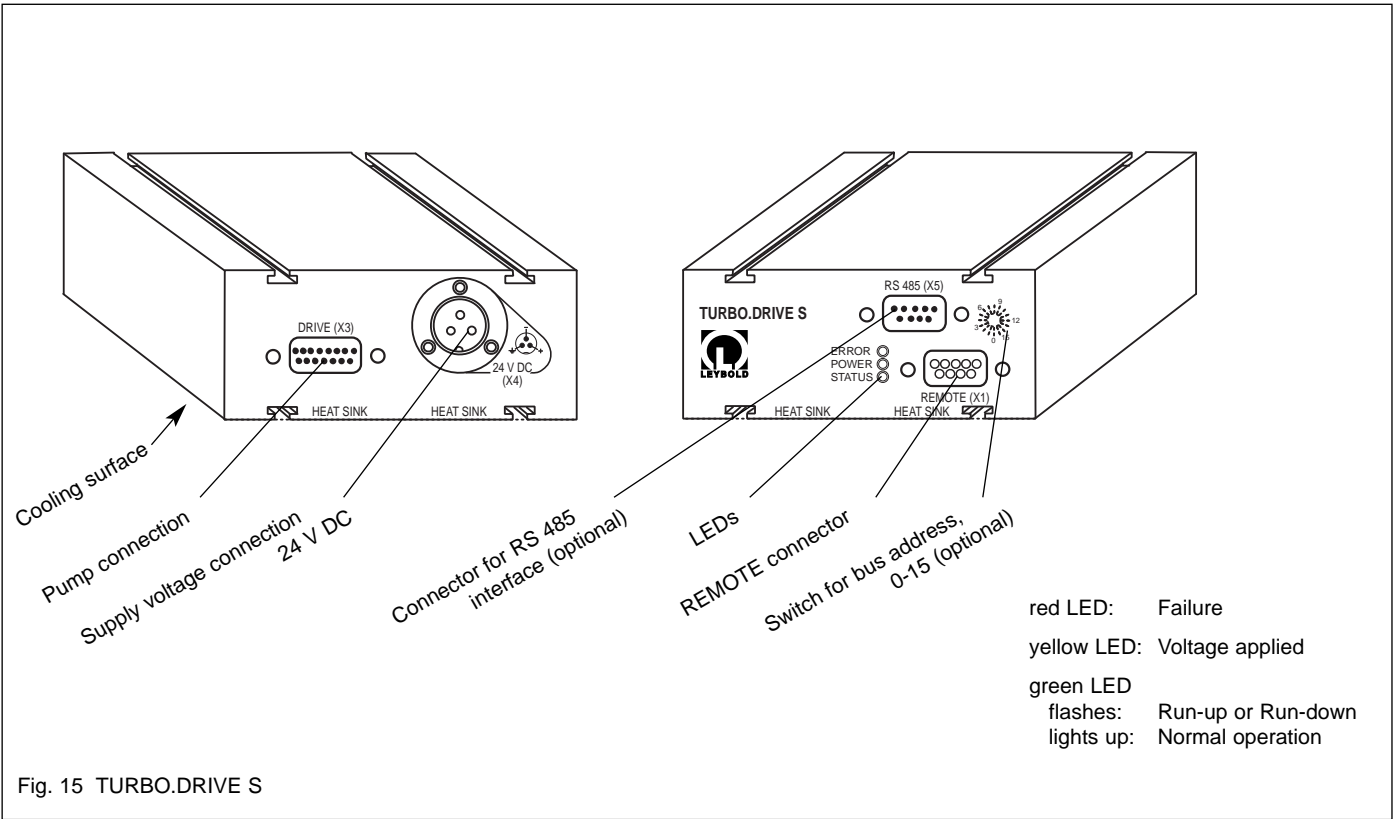

- red LED: Failure
- yellow LED: Voltage applied
- green LED
- flashes: Run-up or Run-down
- lights up: Normal operation

2.6 Electrical connection

The TURBO.DRIVE S frequency converter needed to operate the TURBOVAC TW 250 S has either been integrated in the pump or is a separate unit. For connection examples see Figs. 19 and 20.

Warning



The pump may be operated only with a suitable frequency converter and suitable connector cables.

Route all cables so as to protect them from damage.

Do not expose the pump, the frequency converter or the connections to water.



Disconnect and connect the cable connections only while the pump is turning no longer (green status LED off) and with the mains power switched off (yellow power LED off). Otherwise there is the risk of damaging the TURBO.DRIVE S.

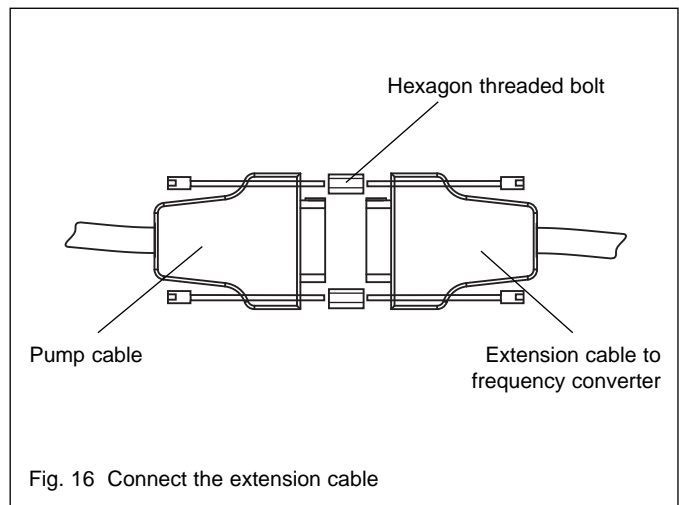

2.6.1 Connecting pump and frequency converter

Only required in the case of a separate frequency converter.

Connect the pump to the frequency converter using a suitable connecting cable (15 way Sub-D plug X3). Connect the Sub-D-plugs with the hexagon threaded bolts UNC 4/40x6 which are provided with the cable.

Make sure that the frequency converter is adequately cooled; for this see also Fig. 17.

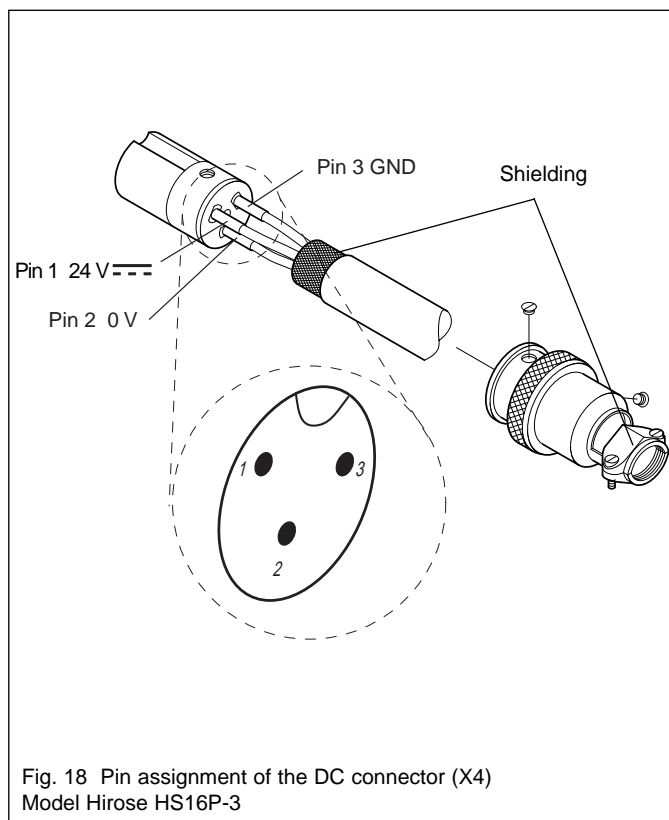
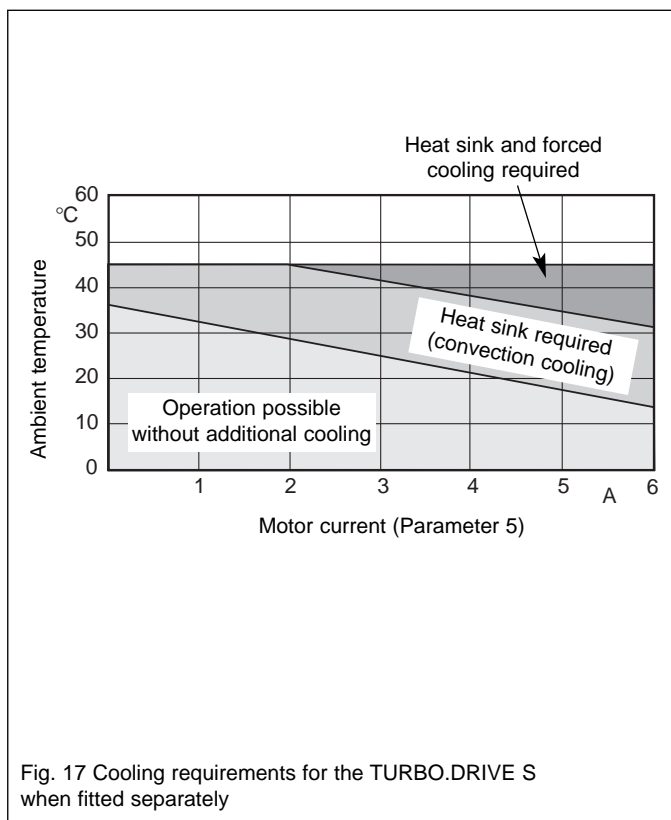

2.6.2 Connecting the power supply

Warning



The frequency converter must only be connected to power supplies which meet the requirements for functional extra low voltage with positive isolation in accordance with IEC 364 (VDE 0100, Part 410, or local regulations) (SELV).

The power supply must meet the requirements given in Section 1.4.3. Peak currents in the kHz range may be present on the DC side. The power supply should have a current limiter or be of the current regulated type.

When connecting several frequency converters to a single power supply, then each frequency converter must be fused separately.

Connect the frequency converter to the 24 V DC power supply via the 24 V DC cable; see Fig. 19.

Caution

Ensure correct polarity.

- Pin 1 + 24 V
- Pin 2 0 V
- Pin 3 GND

A wrong polarity may cause the internal SMD fuse to blow. The fuse can only be changed by the Leybold Service.

Connect the power supply to the mains.

Emergency shutdown: By shutting down the power supply voltage. Please note the information on shutting down and emergency shut down provided in Section "3.2 Shutting down"

2.6.3 Mounting the frequency converter

The frequency converter may be affixed with the aid of the enclosed M4 sliding nuts. The bottom side of the frequency converter must be cooled sufficiently.

If the frequency converter is mounted without the optional heat sink ensure sufficient cooling by other means.

For special requirements please contact Leybold.

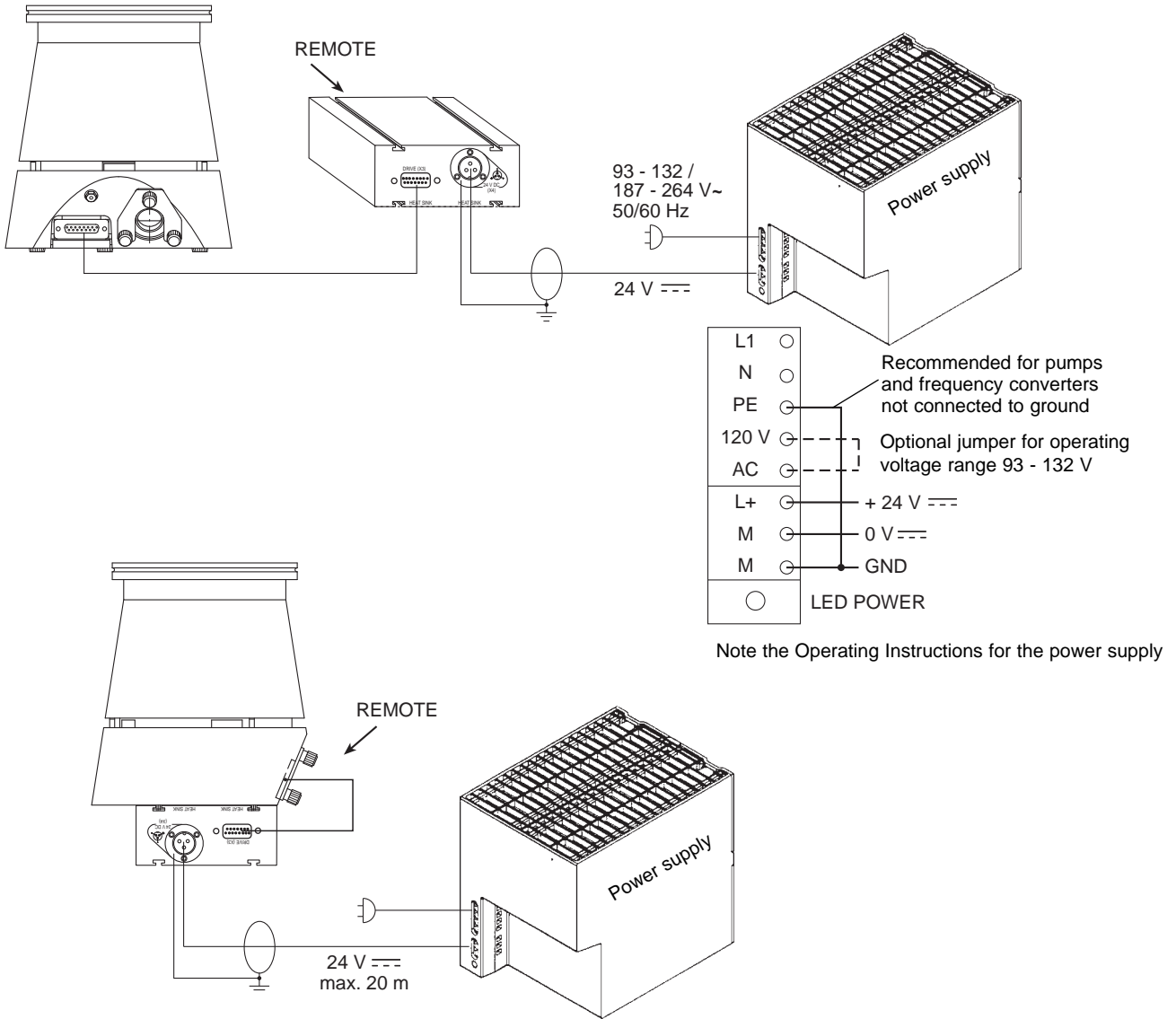

Fig. 19 Connecting the power supply;
top at the separate frequency converter
bottom at the integrated frequency converter

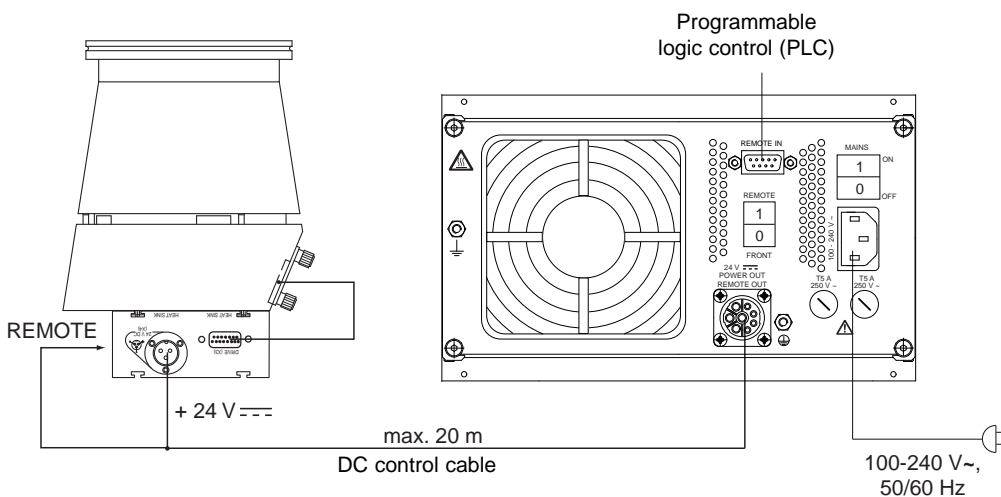
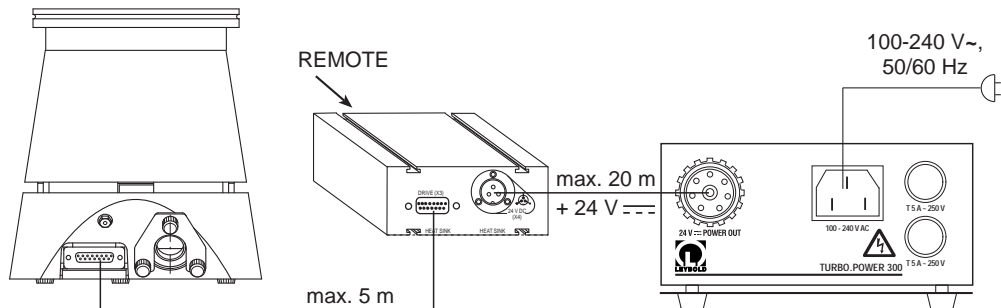

Fig. 20 Examples for connection
 top: TURBOVAC with separate frequency converter to TURBO.POWER 300,
 bottom: TURBOVAC with integrated frequency converter to TURBO.CONTROL 300

Relay status

Input data / status				Output data					Operating mode
Start/stop signal	Pump rotating	Normal frequency $\geq 90\%$ of setpoint frequency	Error is present	Motor drive	Relay NORMAL OPERATION	Relay ERROR	LED STATUS	LED ERROR	Other modes are not possible; they indicate a failure affecting the TURBO.DRIVE S.
Stop	no	no	no	off	passive	passive	off	off	Pump not operating
Stop	yes	no	no	off	passive	passive	flashes	off	Pump is decelerating
Stop	yes	yes	no	off	passive	passive	flashes	off	Just after stop; pump was in the normal operating mode before that
Start	no	no	no	on	passive	passive	off	off	Just after start
Start	yes	no	no	on	passive	passive	flashes	off	Pump is accelerating
Start	yes	yes	no	on	active	passive	green	off	Pump is in the normal operating mode
Stop	no	no	yes	off	passive	active	off	red	Error is present; pump is at standstill
Stop	yes	no	yes	off	passive	active	flashes	red	Error is present; pump is decelerating
Stop	yes	yes	yes	off	passive	active	flashes	red	Error has just occurred
Start	no	no	yes	off	passive	active	off	red	Error is present; pump is at standstill
Start	yes	no	yes	off	passive	active	flashes	red	Error is present; pump is decelerating
Start	yes	yes	yes	off	passive	active	flashes	red	Error has just occurred

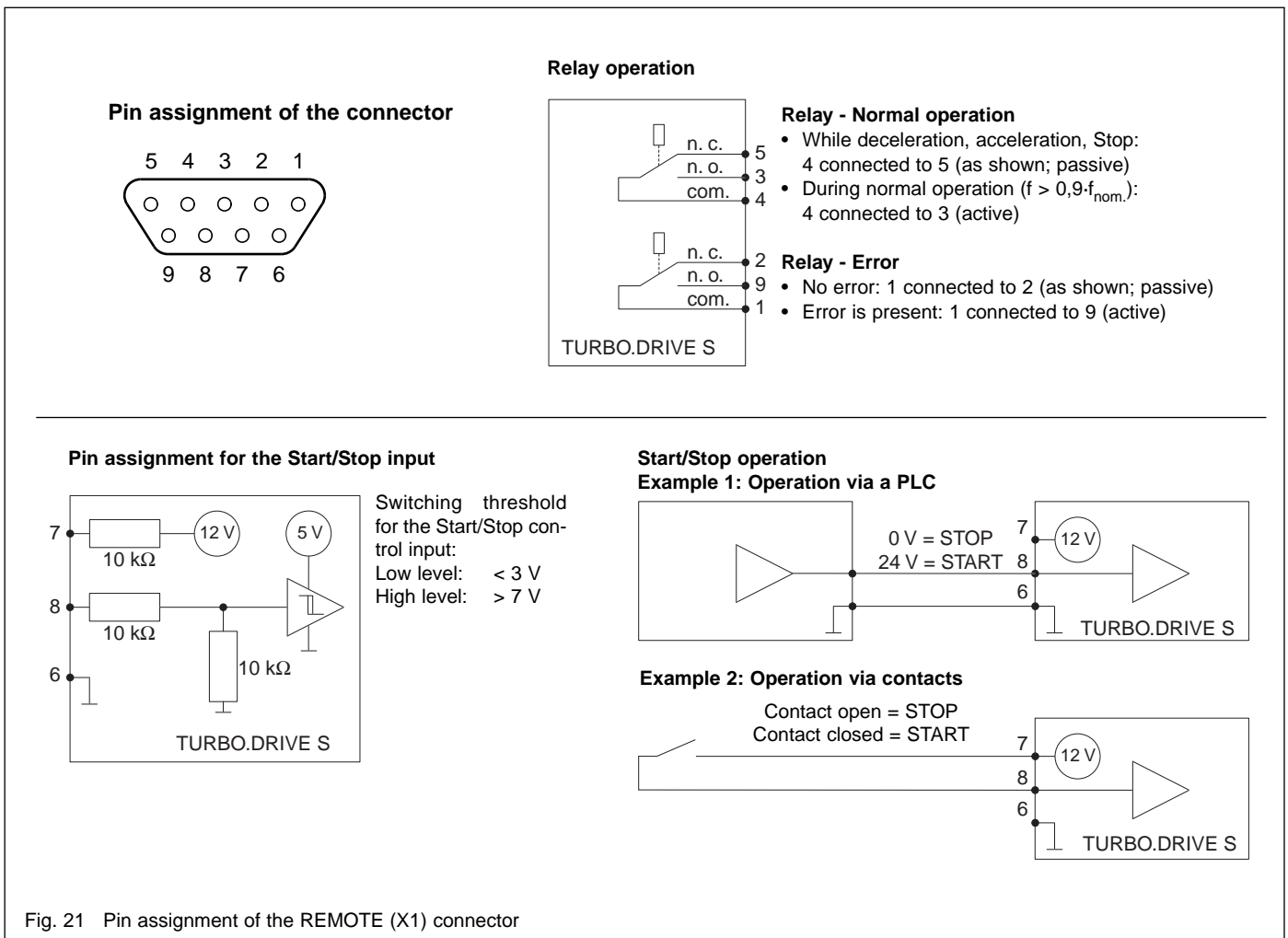

Fig. 21 Pin assignment of the REMOTE (X1) connector

2.7 Interface description

The frequency converter may be equipped with either of the following interfaces (optional):

- RS 232
- RS 485
- Profibus DP

The TURBO.DRIVE S is configured through the parameters according to the parameter list. Pxxx denotes parameter value xxx.

The PC software "TURBO.DRIVE Server" or a PDA display with the software "TURBO.DRIVE Panel" allow convenient access by the user to the parameters of the frequency converter.

For further information on the interfaces refer to Operating Instructions GA 05.281 "Serial Interfaces".

Applications which can be implemented with the aid of the serial interface:

Application	Benefits to the customer	How to do it
Networking of several pumps and other equipment	Savings relating to the costs for signalling cables	With Field Bus systems like RS485 or Profibus
Automation	Savings related to repetitive manual work	For example by a control computer
Avoidance of warnings and warnings before overload operation and early detection of a failing pump	<ul style="list-style-type: none"> • Precise planning for maintenance • Improved reliability of sensitive production processes in a vacuum 	Monitoring of: <ul style="list-style-type: none"> • Motor current P5 • Ball bearing temperature P125 or P127 • Motor temperature P7 • Frequency converter temperature P11
Standby operation	<ul style="list-style-type: none"> • Extending the service life for the ball bearings • Cutting energy consumption 	Reducing the rotor's frequency through P24
Troubleshooting	Quick analysis of problems	Reading of error memories P171 and P176
Slow pressure control by changing the pumping speed	Dispensing with a flow controller	Changing the rotor frequency through parameter 24
Reducing the maximum motor current	Cost savings through smaller power supply units if peak loads can be reduced	With P17, maximum motor current
Starting the pump with a delay if a several consumers are connected to the same PSU	Cost savings through smaller power supply units if peak loads can be reduced	With P36, delay
Frequency converter as a simple pressure gauge, since motor current is dependent on the vacuum conditions	Dispensing with pressure gauges	Monitor motor current P5; second function for "Normal Operation" relay: relay switches as soon as the motor current threshold is tripped Adjust second function: P29 Set motor current threshold: P27
Lowering the normal operation threshold	Normal operating mode is attained faster, processes can be started faster	Reduce frequency threshold through P25

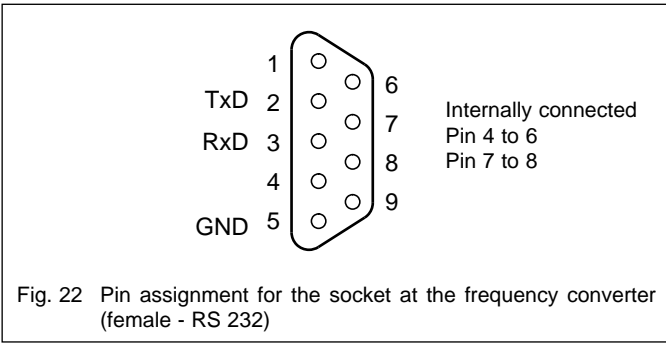

Fig. 22 Pin assignment for the socket at the frequency converter (female - RS 232)

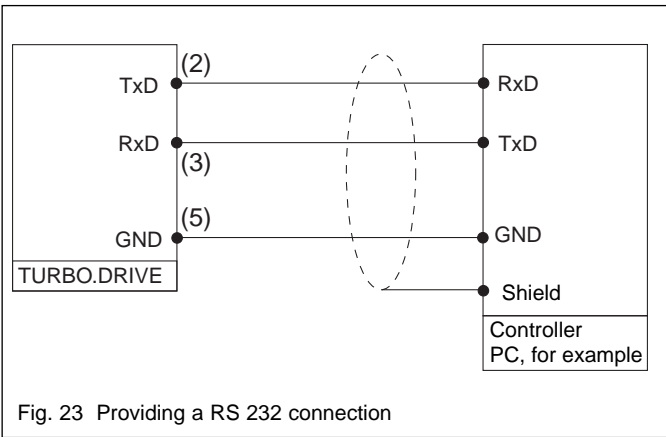

Fig. 23 Providing a RS 232 connection

RS 232 interface

Standards	DIN 66020
Protocol	acc. to VDI/VDE 3689
Transmission rate	19200 baud fixed
Response delay	default setting 10 ms (parameter 180)
Address range	non-addressable
Max. cable length	5 m
Nominal voltage level (see also "Standards")	at the receiver logic "0": 3 ... 15 V logic "1": - 3 ... - 15 V
Interface connector	9 way Sub-D type, socket on the instrument (female) thread UNC4-40

Note: If on the controlling side an interface in accordance with the PC standard is present, then a commercially available straight through cable may be used.

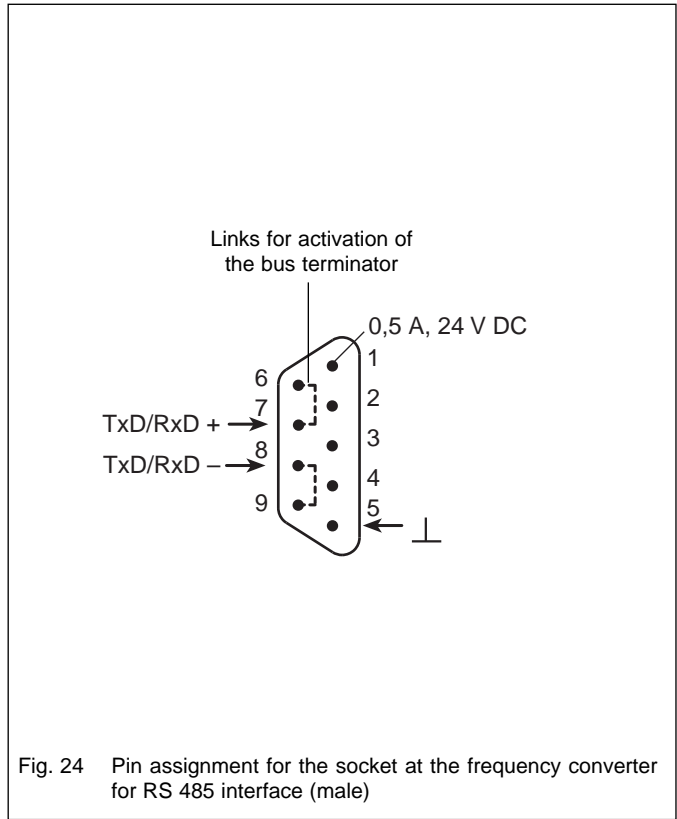

Fig. 24 Pin assignment for the socket at the frequency converter for RS 485 interface (male)

RS 485 interface

Standards	ISO 8482, EIA 485
Protocol	acc. to VDI/VDE 3689
Transmission rate	19200 baud fixed
Response delay	default setting 10 ms (parameter 180)
Address range	0 ... 15
Max. cable length	50 m (with bus termination)
Type of cable	2 wire twisted pair (twisted pair cable)
Differential voltage levels (see also "Standards")	logic "0": transmitter: 1.5 ... 5 V receiver: > 0.3 V logic "1": transmitter: - 1,5 ... - 5 V receiver: ≤ - 0,3 V
Interface connector	9 way Sub-D type, plug on the instrument (male) thread UNC4-40

Note: After having changed the bus address through the rotary switch, the frequency converter must be switched off (yellow power LED off) and then on again so as to enable the new address setting.

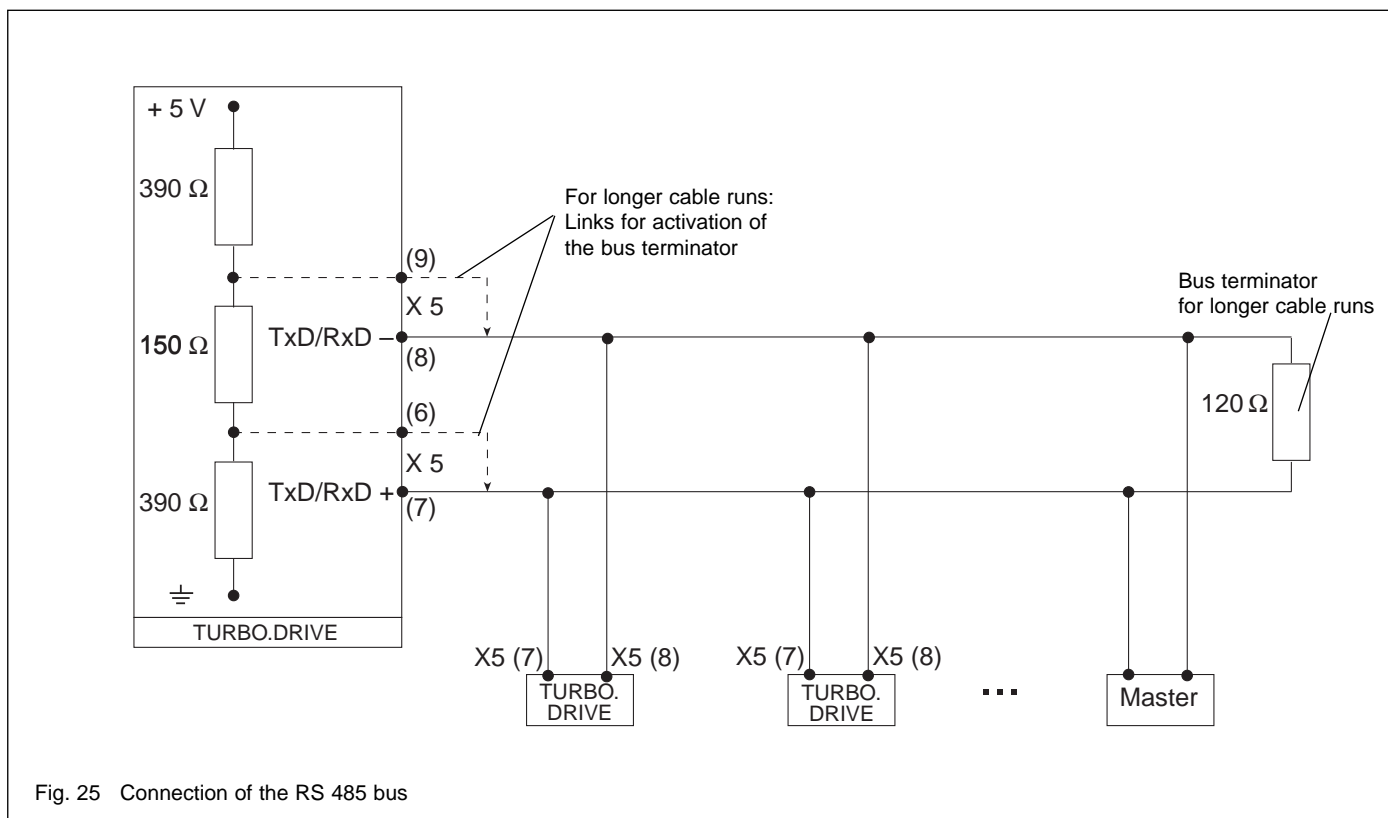

Fig. 25 Connection of the RS 485 bus

Profibus DP

The Profibus DP used has been defined in the standards EN 50170, DIN 19245-1, -3, VDI/VDE 3689.

For more information on the Profibus system:

"The Rapid Way to Profibus",
 Manfred Popp, Profibus Nutzerorganisation e.V.,
 Germany
 P/N 4.072

Parameter list

No.	Designation	Range	Unit	Default	Format	r/w	Description
0	Dummy parameter	-	-	-	U16		No function
1	Type of frequency converter	130 / 131	-	-	U16	r	TURBO.DRIVE S = 130 TURBO.DRIVE L = 131
2	Software version	2.x.x	-	-	U16	r	
3	Actual rotor frequency	0...1300	Hz	-	U16	r	
4	Actual converter supply voltage	18...30	V	-	U16	r	Nominal value for TURBO.DRIVE S: 24V
5	Setpoint for the motor current	0... 60	0,1A	-	U16	r	
7	Actual motor-temperature	0...150	°C	-	U16	r	Measured coil temperature for the motor
8	Permanently save the changed parameter data in the EEPROM	-	-	-	U16	w	A write command will cause the data to be saved. The parameter value itself is not processed and saved.
11	Actual converter temperature	0...150	°C	-	U16	r	Measured internal converter temperature
12	Operating mode for Start/Stop	0...2	-	0	U16	r/w	P12 = 0 (default): via REMOTE (X1); P12 = 1: via serial interface P12 = 2: Start: REMOTE (X1) at Start and serial interface sends Start signal Stop: REMOTE (X1) at Stop or serial interface sends Stop signal
17	Max value setting for motor current	5 ... 45	0,1 A	45	U16	r/w	Maximum permissible motor current for TW 250 S
18	Nominal pump frequency	750...1200	Hz	860	U16	r	Highest permissible frequency
19	Minimum setpoint frequency for the pump	375..600	Hz	450	U16	r	Lowest permissible frequency
20	Minimum frequency level	375..600	Hz	450	U16	r	When the pump is accelerating this frequency must be reached within the maximum passing time (P183).
23	Pump type	0...4	-	-	U16	r	2 = TW 250 S
24	Setpoint frequency	P19 ... P18	Hz	860	U16	r/w	Adjustable between P19 to P18
25	Frequency dependent normal operation level	0..100	%	90	U16	r/w	If P29 = 0: Defines the normal operation level. Normal operation if $P3 \geq P24 \times P25$
27	Motor current dependent normal operation level	5...75	0,1 A	20	U16	r/w	If P29 = 1: Defines the normal operation level. Normal operation if $P5 \leq P27$
29	Selection of the normal operation function	0 / 1	-	0	U16	r/w	Normal operation relay function: 0 = frequency dependent (see P25) 1 = current dependent (see P27)
32	Maximum run up time	30...2000	s	720	U16	r/w	Max. permissible time during which the pump must attain the normal operation threshold ($P24 \times P25$) with the start signal present
36	Start delay time	0...255	0.1 min.	0	U16	r/w	Pause time after the Start command until the pump's drive is started
125	Current bearing temp.	0...150	°C	-	U16	r	Measured bearing temperature (identical to P127)
127	Current bearing temp.	0...150	°C	-	U16	r	Measured bearing temperature (identical to P125)

No.	Designation	Range	Unit	Default	Format	r/w	Description
132	Bearing temperature shutdown level	30...150	°C	80	U16	r	Max. permissible bearing temperature P125 > P132 causes the pump to be switched off
133	Motor temperature shutdown level	30...150	°C	100	U16	r	Max. permissible motor temperature P7 > P133 causes the pump to be switched off
171	Error code memory for the last 8 error events Error codes see error table 4.3	0...8		0	Array 0..7 U16	r	Sequential permanent memory; the last error code which has occurred is saved at the memory location with the index 0, the oldest is at index 7
176	Error operating hours memory for the last 8 error events	0...19 years	0.01 h	-	Array 0..7 U32	r	Analogous to P171 (error code memory)
180	Response delay time	2...19	msec	10	U16	r/w	Pause time between received and transmitted USS protocol string of the frequency converter's serial interface. We recommend not to change the default setting (10 ms)
183	Max. passing time	10...2000	s	500	U16	r	Max. permissible time during which the pump must - with the start signal present - have passed through the critical speed range between 60 Hz and P20
184	Converter operating hours counter	0...19 Years	0,01h	-	U32	r	Totals the operating hours for the converter when the pump's drive is active
303	Pump status word	-	-	-	U16	r	Meaning of the bits: Bit 0 = 1 Normal operation Bit 1 = 1 Ready for switch on Bit 2 = 1 Speed is increasing Bit 3 = 1 Speed is dropping In case of an error P303 has the value of 0 (not ready to be switched on)
312	Cat. No. code	0 ... 65535	-	-	U16	r	800070V0002 = 7002 800070V0003 = 7003 etc.
315	Serial No. code	1 ... 231-1	-	-	U32	r	The 9 least significant bits of the original serial No.
316	Hardware identifier	0...100	-	-	U16	r	Hardware version index of the converter

Error codes for parameter P171

Code	Type of error	Description of the error
0	No error	-
1	Overspeed error	Nominal speed of the pump (P 18) has been exceeded by over 10%
2	Pass through time error	Max. time for passing through the critical frequencies of 60 Hz to P20 has been exceeded: 60 Hz < P3 < P20 after P183 has elapsed with the start signal present
3	Bearing temperature error	Maximum bearing temperature has been exceeded: P125 > P132; P127 > P132
4	Short circuit error	Short circuit in the pump's motor or the connecting cable
5	Converter temperature error	Maximum temperature for the converter has been exceeded: P11 > 75°C
6	Run up time error	Max. time after which the pump must enter its normal operation mode has been exceeded: P3 < P24 x P25 after P32 has elapsed with the start signal present
7	Motor temperature error	Maximum motor temperature has been exceeded: P7 > P133
8	Pump error	Pump could not be identified or no pump is connected.

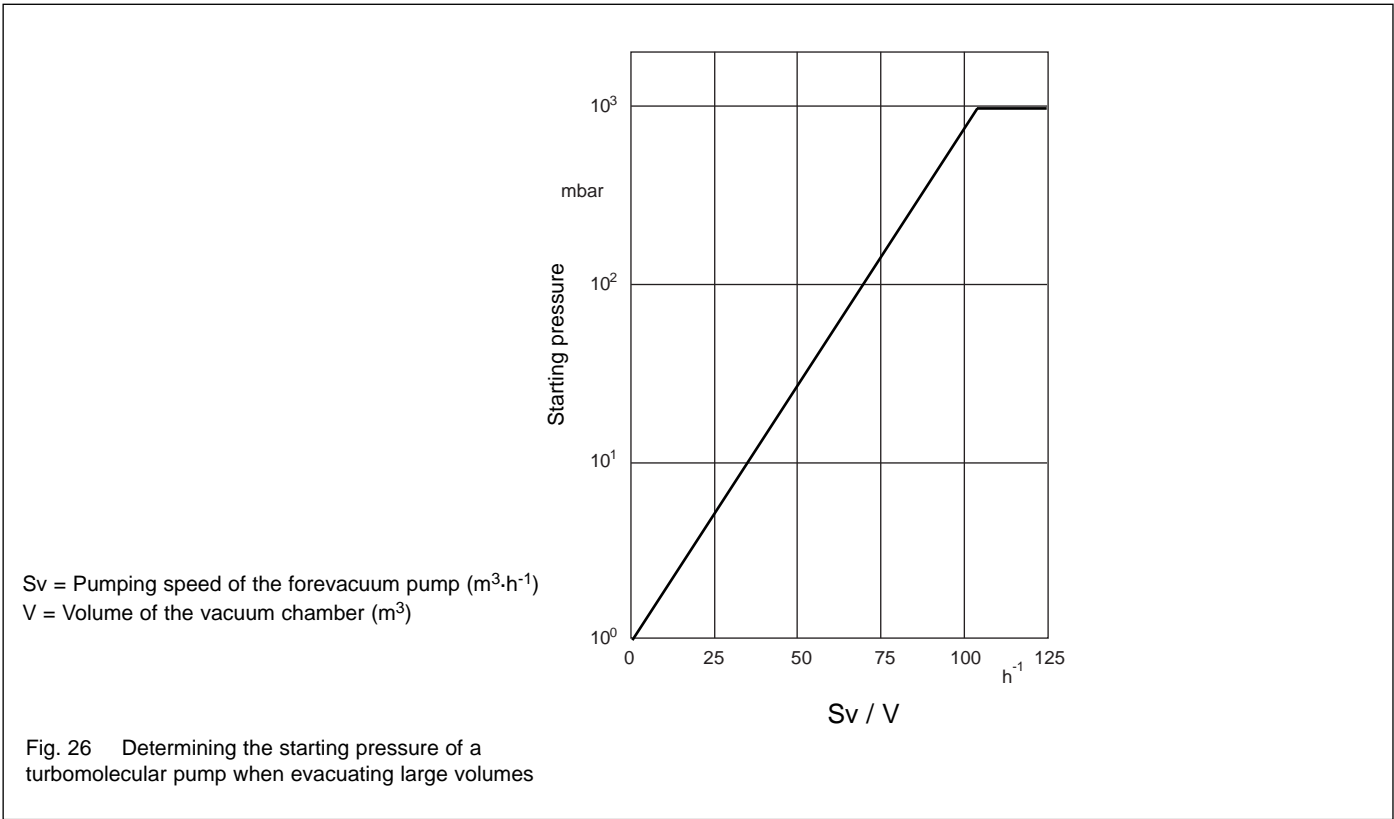

3 Operation

Warning



The turbomolecular pump must only be operated in the proper condition and under the conditions described in the Operating Instructions.

Caution

Exposure of the pump to accelerating forces must be avoided or reduced to such an extent that the rotor unit will not be excited by vibrations. In the case of critical applications you must consult our Applications Dept. first.

The direction of rotation for the pump has been checked by Leybold. For this reason a further check by the user is **not required** and must, for safety reasons, **not** be done on the opened system.

3.1 Switching on

Switch on the 24 V DC power supply. The yellow LED at the frequency converter lights up.

The maximum starting pressure for the turbomolecular pump can be read from the graph in Figure 26.

Switch on the turbomolecular pump at the frequency converter

- via pins 7 and 8 of the socket REMOTE (X1) (see Fig. 9) (For example via a remote control or with the aid of the plug with integrated ON/OFF switch: see Section 1.3 Ordering data).
- by a start command via the interface; see Section 2.7.
- For the power supply units offered or recommended by Leybold: If the contacts 7 and 8 at the REMOTE (X1) connector are closed the pump starts automatically when the DC voltage is switched on (provided parameter 12 is set to 0).

The turbomolecular pump runs up. The green LED flashes. When the pump reaches normal operation the green LED lights up permanently.

Avoid the influences of shock and vibration when the pump is running.

Caution

If the pump was exposed to impacts, for example by an earthquake, during start up take note especially of any apparent noises. In the case of any unusual noises coming from the pump, inform Leybold Service.

Warning



During operation the pump can become so hot that there is a danger of burns (up to approx. 80°C, 176 °F).

Warning



After a mains power failure the pump can run up automatically once more.

3.2 Shutting down

Switch off the pump at the frequency converter.

- via contacts 7 and 8 of the socket REMOTE (X1), if parameter 12 = 0.
- apply a stop command via the interface, if parameter 12 = 1 or 2.
- for the power supply units offered or recommended by Leybold switch off the DC voltage.

After switching off, the green status LED will flash until the rotor of the turbomolecular pump is at standstill. This may take several minutes.

With the DC power supply off, the turbomolecular pump will act as a generator supplying the frequency converter with energy as indicated by the yellow power LED. At speeds approximately below 200 Hz, there will not be enough power any more for the LEDs, i.e. the pump may still turn with out any of the LEDs being on.

Switch off the forevacuum pump.

When using oil-sealed forevacuum pumps, vent the turbomolecular pump before it comes to a stop; refer to Section 3.3.

When using TRIVAC pumps the built-in anti-suckback valve will close automatically, shutting off the forevacuum line. In forevacuum pumps without a vacuum retention valve, close the valve in the forevacuum line.

When the system is not operating, ensure that neither ambient air nor cleaning media can enter the pump.

If a failure occurs the turbomolecular pump will be shut down automatically. The red LED at the frequency converter lights up.

Warning



Under vacuum conditions the pump may take up to one hour to run down, when venting to atmospheric pressure it may take up to one minute. During the time the pump is running down, the green LED at the frequency converter will flash, indicating that the rotor has not yet arrived at standstill.

When shutting down by **switching off the power supply voltage**, there will be only enough power for the LEDs down to a speed of the pump of approximately 200 Hz. Thus the pump may still turn without a LED being on. For this reason, when switching off without venting, wait for approximately 15 minutes after the LEDs have turned off until the pump has arrived at standstill.

Warning



Unplug any connectors only when the mains voltage is switched off **and** the pump does no longer turn (the green LED is off).

Emergency shut down

In the case of an emergency shut down, the pump is switched off as described above. The rotor of the turbomolecular pump may be stopped faster by venting the pump.

3.3 Venting

As to suitable gases, see Chapter 2.5.

Venting Methods

There are three different methods of venting the turbomolecular pump.

In the case processes requiring a purge gas, the pump must be vented via the **purge gas and venting valve** when shutting the pump down.

When additionally venting the vacuum chamber, the venting function of the purge gas and venting valve must be opened before opening the chamber valve. This will ensure the presence of a higher pressure in the area of the ball bearings compared to the remaining vacuum area. This will prevent particles, dust or aggressive gases from being forced through the bearings into the not yet vented motor chamber of the pump.

Cautious venting of the pump is possible from the **high vacuum side**, since here the bearing forces will be

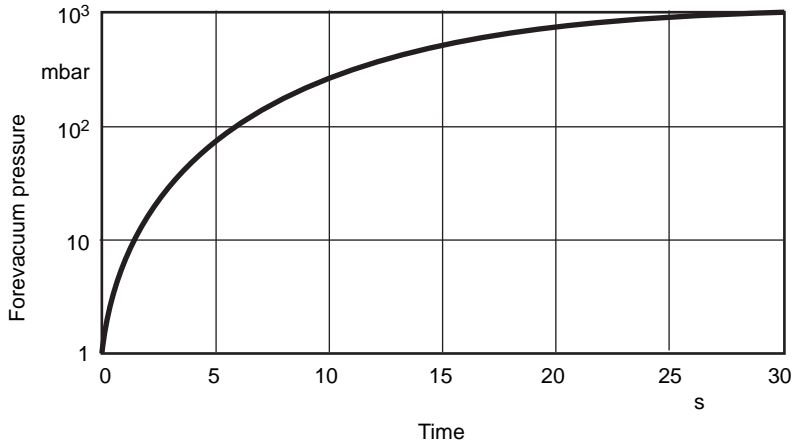

Fig. 27 Maximum rise in pressure

lowest. When doing so, no free jet of gas must be allowed to form on the rotor so as to avoid exposing the rotor to additional forces.

When venting the pump through its **foreline connection**, neither oil nor particles may be entrained in the gas flow from the forevacuum side into the pump.

Speed of the Pressure Rise

All turbomolecular pumps may be vented at full speed. However, the pressure must not increase faster than specified through the pressure rise curve.

The pump must be vented significantly slower when there is the risk of particles entering into the pump from the process. During venting, the flow must be of the laminar type in both the vacuum chamber and the turbomolecular pump.

The speed of the pressure rise during venting of the running pump will greatly influence the load on the rotor/stator pack and the bearings. The slower the pump is vented, the longer the service life of the bearings will be.

The pump must not be vented to pressures above atmospheric pressure.

3.4 Bakeout

For TURBOVACs with CF flange

If pressures in the range of 10⁻⁸ mbar or below are to be developed, the vacuum chamber and the components installed therein will have to be baked out. In addition, the TURBOVAC can be baked out using the flange heater provided for this purpose.

Protect the rotor against intensive, direct heat radiation. When baking out at the forevacuum side – at a sorption trap, for example – ensure that the components attached direct are not heated to more than 100 °C (212 °F).

The forevacuum pump must be in operation so as to eliminate the vapors liberated at the sorption trap.

3.5 Removing the pump from the system

Shut down the pump and vent as described in Sections 3.2 and 3.3.

Warning



If the pump has previously handled hazardous gases, implement the proper precautionary measures before opening the intake or exhaust connection.



If necessary, use gloves, a respirator and/or protective clothing and work under an exhaust hood.



Disconnect the pump only when it has come to a full stop. The green LED at the frequency converter must have gone out.

When shutting down by switching off the power supply voltage, wait for approximately 15 minutes after the LEDs have turned off until the pump has arrived at standstill.

Then switch the mains power off and wait until the yellow power LED is off. Then only disconnect any cable connections.

The pumps may be contaminated with process gases. These gases may be toxic and hazardous to health. In addition, deposits with similarly dangerous properties may have formed. Many of these gases and deposits form acids when they come into contact with humid air. This will result in serious corrosion damage to the pump.

To avoid health hazards and corrosion damage when the pumps are detached from the system, fasten a container of desiccant under the transport cover of the high-vacuum connection and then close the pump immediately at all flange connections. Store the pump, with a desiccant, in an air-tight PE bag.

Corrosion damage due to faulty packing will nullify the guarantee.

Pack the pump so that it cannot be damaged during shipping and storage. Pay particular attention to protection for the flanges and the electrical plug.

Observe the instructions in Section 4.2 if you forward the pump to Leybold.

Caution

Pumps with integrated frequency converter need to be shipped to the LEYBOLD Service with the frequency converter. Pump and frequency converter must not be separated.

If in exceptional cases you only want to replace a frequency converter which is suspected of being defective and do not want to remove the pump from your system, please contact the LEYBOLD Service first.

4 Maintenance

We recommend a standard bearing change after 20,000 operating hours at the latest. Moreover, we are recommending an exchange of the rotor unit after 45,000 operating hours at the latest.

Such maintenance work can only be done by the LEYBOLD Service. If required contact the LEYBOLD service center nearest to your location. You can find the address on our internet page www.leyboldvac.de.

At high pump loads - for example during cyclic operation, at high gas throughputs or at high ambient temperatures - the aforementioned maintenance work should be carried forward (at the latest after 15,000 and 40,000 hours respectively).

When using purge gas valves

Depending on the degree of contamination of the purge gas used the filter will clog and will have to be exchanged (our experience indicates that this will become necessary after 1 to 6 months).

When using an adsorption trap

Regenerate or renew the adsorption agent regularly; refer to the operating instructions provided with the trap.

Caution

The pump must only be opened by such persons who have been authorised by Leybold to do so.

4.1 Cleaning

If required clean the turbomolecular pump with a dry cloth.

4.2 Service by LEYBOLD

Whenever you send a pump to Leybold, indicate whether the pump is contaminated or is free of substances which could pose a health hazard. If it is contaminated, specify exactly which substances are involved. You must use the form we have prepared for this purpose; we will forward the form on request.

A copy of the form is printed at the end of these operating instructions: „Declaration of contamination of vacuum equipment and components“. Another suitable form is available from the Leybold homepage: <http://www.leyboldvac.de> under the headline “customer service”.

Attach the form to the pump or enclose it with the pump.

This statement detailing the contamination is required to satisfy legal requirements and for the protection of our employees.

Pumps which are not accompanied by a contamination statement will be returned to the sender.

5 Troubleshooting

Warning



When the connector cable is attached, the outputs at the frequency converter are not free of voltage.

Before you start searching for the source of the problem, you should carry out a few simple checks:

Are the connections in good working order?

- Mains connection,
- 24 V DC cable to the frequency converter,
- Connector cable between the frequency converter and the pump

Is the forevacuum pressure sufficient?

After having removed the cause for the error reset the error message at the TURBO.DRIVE S:

- In case of errors with error codes 1 to 7 by applying a STOP signal via the socket REMOTE (X1) or a reset sequence via the serial interface or by switching the mains power off.
- In case of error code 8 by switching the mains power off.

The error codes can only be read if a serial interface is present..

The following table has been provided as a guide when determining the causes of errors.

To remove possible faults, staff having different qualifications is required:

- **Operator** of the system
- Qualified **maintenance staff** of the system operator or qualified staff from the vendor erecting the system
- Staff from **Leybold-Service**

In some cases also a combination of the above will be needed, for example, check by the operator, rectification of the fault by maintenance staff.

Malfunction	Possible cause	Corrective action	Responsible
Red ERROR LED is on: Error code1: Overspeed error	EMC influence TURBO.DRIVE faulty	Check connecting cable, insert it properly Switch the power supply voltage off and then on again Replace frequency converter.	Operator/ maintenance staff Operator Maintenance staff/ Leybold service
Red ERROR LED is on: Error code 2 + 6: pass through timer error and run up time error • Pump runs up too slowly • Pump loses its speed	Forevacuum or high-vacuum pressure too high. Gas volume too great. Power supply overloaded Bearing defective.	Check the forevacuum pump and use a different forevacuum pump if necessary. Seal leak; install a higher-capacity vacuum pump if necessary. Reduce the number of consumers or use a stronger power supply or switch on the consumers one after the other. Repair the pump.	Operator/ maintenance staff Maintenance staff Operator/ maintenance staff Leybold service
Red ERROR LED is on: Error code 3 + 7: bearing temperature error and motor temperature error	Forevacuum pressure too high. Gas volume too great or leak in the system. Fan defective. Ambient temperature too high. Bearing defective. Cooling water too hot.	Check the forevacuum pump and use a different forevacuum pump if necessary. Seal leak; install a higher-capacity vacuum pump if necessary. Replace the fan. Feed cooler air to the pump or install water cooling. Repair the pump. Observe cooling water data.	Operator/ maintenance staff Maintenance staff Leybold service Maintenance staff Leybold service Operator/ maintenance staff

Malfunction	Possible cause	Corrective action	Responsible
Red ERROR LED is on: Error code 4: Short circuit error	Short circuit in the pump's motor Short circuit in the connecting cable	Repair the pump. Check to see if the connecting cable is undamaged, exchange it if required.	Leybold service Operator/ maintenance staff
Red ERROR LED is on: Error code 5: converter temperature error	TURBO.DRIVE S integrated in the pump: Inadequate cooling of the pump; operation at too high loads Separate TURBO.DRIVE S: Ambient temperatures too high Inadequate cooling of the TURBO.DRIVE S Cooling water too hot.	See corrective action for error code 3 + 7. Improve the cooling situation: Avoid exposure to the heat generated by other equipment. Observe cooling water data.	– Maintenance staff/ Operator/ maintenance staff
Red ERROR LED is on: Error code 8: pump error TURBO.DRIVE S can not detect the type of connected pump.	Pump not connected to TURBO.DRIVE Wrong connector cable pump - frequency converter. Power supply builds up the DC too slowly Power supply overloaded	Check connecting cable Use standard cable; see Section 1.3) Use power supply recommended by Leybold Reduce the number of consumers when switching on or use a stronger power supply.	Operator Maintenance staff Maintenance staff Operator/ maintenance staff
Yellow power LED is not on.	No DC power Current surge is too high. DC power miswired. Frequency converter defective.	Check cables and power supply. Switch on the loads for the power supply one after the other; if required adapt parameter 36 Ensure correct polarity of the DC cable. Replace frequency converter. The following may damage the frequency converter: • Disconnection of the DC cable while the pump was still rotating • Non-compliance with the note related to connecting several pump to a single power supply.	Operator/ maintenance staff Operator/ maintenance staff Maintenance staff Maintenance staff/ Leybold service

Malfunction	Possible cause	Corrective action	Responsible
Turbomolecular pump does not start, ERROR LED does not light.	Operation mode set wrongly, e. g. with TURBO.DRIVE Panel or Server.	Change parameter 12.	Operator/ Maintenance staff
	Interface protocol error	Use USS protocol.	Operator/ Maintenance staff
	No communication via the serial interface.	Connect bus as shown in Section 2.7. Adjust response delay time.	Maintenance staff
	REMOTE connector (X1) connected wrongly. Wrong Profibus address set.	Connect as shown in Fig. 21. Set address between 0 and 126	Maintenance staff Operator/ Maintenance staff
Turbomolecular pump produces loud running noises and vibrations.	Rotor out of balance.	Balance the rotor.	Leybold service
	Bearing defective.	Replace the bearing.	Leybold service
Turbomolecular pump does not reach ultimate pressure.	Measurement instrument defective.	Inspect the measurement sensor.	Operator/ Maintenance staff
	Measurement sensors soiled.	Clean or replace the sensors.	Maintenance staff
	Leaks at the equipment, lines or the pump.	Check for leaks.	Maintenance staff
	Pump soiled.	Clean the pump.	Leybold service
	Forevacuum pump provides insufficient pumping speed or ultimate pressure which is too high.	Check the ultimate pressure of the forevacuum pump and install a higher-capacity vacuum pump if necessary.	Operator/ maintenance staff
Frequency parameters programmed wrongly.	Check parameters.	Operator/ Maintenance staff	
Green LED blinks, yellow LED lights up weakly.	Frequency converter defective.	Wait for pump standstill (several minutes), then switch off the power supply for 5 seconds and switch it on again.	Operator
Running pump can not be stopped via X1.	Pump has been started via the serial interface, the interface controls the pump.	Disconnect the DC supply or connect serial interface and stop via bus. Check parameter 12.	Operator/ Maintenance staff

6 Spare parts

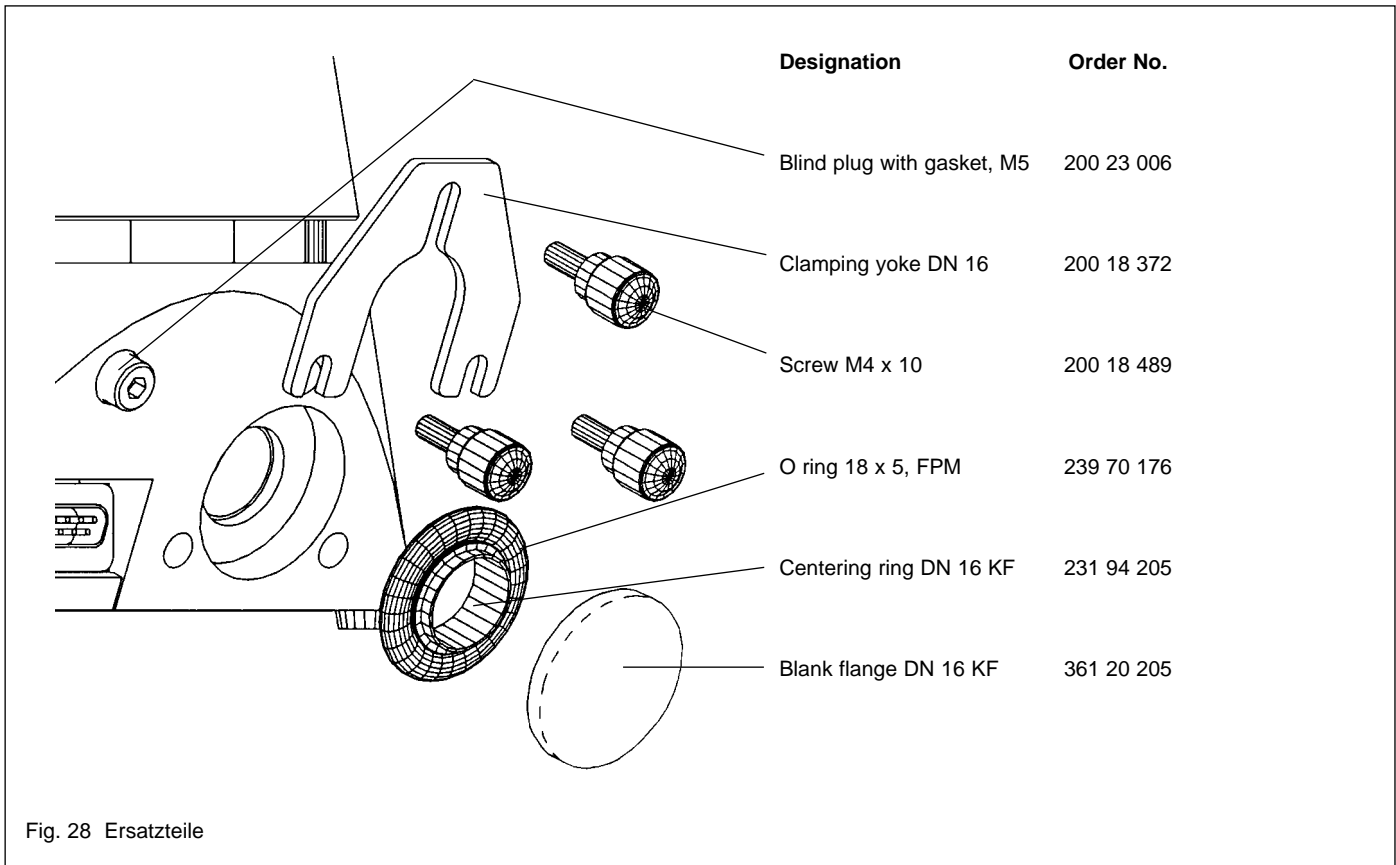

Fig. 28 Ersatzteile



EEC Manufacturer's Declaration

in the sense of EEC Directive on Machinery 89/392/EEG, Annex IIb

We - LEYBOLD Vakuum GmbH - herewith declare that operation of the incomplete machine defined below, is not permissible until it has been determined that the machine into which this incomplete machine is to be installed, meets the regulations of the EEC Directive on Machinery.

At the same time we herewith certify conformity with EEC Directive on Low-Voltages 73/23/EEG.

When using the appropriate Leybold accessories, e.g. connector lines, valves, or fans, and when powering the pump with the specified Leybold frequency converters, the protection level prescribed in the EMC Guidelines will be attained.

Designation: Turbomolecular pump

Model: TW 250 S

Cat. Nos.: 113 52, 114 37,

800150V0007 /09 /11 /12 /13 /14 /16

Applied harmonized standards:

- | | |
|---------------------|-----------|
| • EN 292 Part 1 & 2 | Nov. 1991 |
| • EN 1012 Part 2 | 1996 |
| • EN 60 204 | 1993 |
| • EN 61 010-1 | 1993 |

Applied national standards and technical specifications:

- | | |
|----------------|-----------|
| • DIN 31 001 | Nov. 1984 |
| • DIN ISO 1940 | Dec. 1993 |

Cologne, March 6, 2003



Dr. Beyer, Design Dept. Manager

Cologne, March 6, 2003



Adamietz, Design Department Manager
Turbomolecular pumps



Declaration of Conformity

as defined by the EMC guideline 89/336/EWG
with revisions 91/263/EWG and 93/68/EWG

Product: TURBO.DRIVE S



RIR-TDS2-EMV

2000-12-07

We herewith declare sole responsibility for the product

1. Product: Inverter
2. Manufacturer: Indramat Refu GmbH
Uracher Straße 91
72555 Metzingen / Germany
3. Type: TURBO.DRIVE S,
Cat. Nos.: 800070Vxxxx,
161 11, 136 31
4. including the following options: RS 232 interface, RS 485
interface, integrated Profibus DP, built on heat sink
5. from date of manufacture: 2000-12-01
6. Applied standards: EN 50081 Part 2: Electromagnetic
compatibility (EMC) / Generic
emission standard
EN 50082 Part 2: Electromagnetic
compatibility (EMC) / Generic
immunity standard 06/93

meet the requirements outlined in the EG requirements on
89/336/ EWG (EMC guideline) with revisions 91/263/EWG and
93/68/EWG.

Explanation

Maintaining the EMC guideline assumes an EMC adapted
installation of component within the plant or machine.

Test were run using a typical construction in a test assembly
that conforms with the standards. The legal requirements
made of resistance to interference and resistance to emission
of interference limit values and standards are outlined in the
above-referenced documentation.

This Indramat Refu product is intended for installation into an
end product. The test results are not applicable to every instal-
led state in every end product. This declaration does not there-
fore guarantee the EMC characteristics of the end product.

Metzingen, 2000-12-07

Michael Kimmich
Head of Quality Management

Stephan Scholze
Head of Development

We reserve the right to make changes in the conformity declaration.
Presently applicable edition can be obtained upon request.

Indramat Refu GmbH
Uracher Straße 91 • D-72555 Metzingen
Phone +49 (0) 71 23 / 9 69-0 • Fax +49 (0) 71 23 / 9 69-120





Declaration of Conformity

as per EG Low-Voltage Guidelines 73/23/EWG,
Attachment III B

Product: TURBO.DRIVE S



RIR-TDS2-NSR

2000-12-07

We herewith declare sole responsibility for the product

- 1. Product: Inverter
- 2. Manufacturer: Indramat Refu GmbH
Uracher Straße 91
72555 Metzingen / Germany
- 3. Type: TURBO.DRIVE S,
Cat. Nos.: 800070Vxxxx,
161 11, 136 31
- 4. including the following options: RS 232 interface, RS 485
interface, integrated Profibus DP, built on heat sink
- 5. from date of manufacture: 2000-12-01
- 6. Applicable standard: EN 61010 Part 1: Safety
requirements for electrical
equipment for measurement,
control and laboratory use., 03/94

EN 60204 Part 1: Safety of
machinery - Electrical equipment of
machines, 06/93

including the required accessories, as agreeing with EG guide-
lines 72/23/EWG, and 93/68/EWG.

Explanation

This product is a component intended for further assembly.
Due to the features resulting therefrom, the product cannot
initially meet requirements made of finished products, machi-
nes or plants. It must thus be used for mounting/assembly only.

An evaluation of electrical and mechanical safety, environ-
mental conditions (e.g., extrinsic objects and/or humidity) must
be performed after mounting/assembly in the finished product.

The EMC characteristics of this product can change in a moun-
ted/ assembled state. An EMC check must thus be made for
the finished product (final unit, machine or plant) by the manu-
facturer of the finished unit, machine or plant.

Metzingen, 2000-12-07

Michael Kimmich
Head of Quality Management

Stephan Scholze
Head of Development

We reserve the right to make changes in the conformity declaration.
Presently applicable edition can be obtained upon request.

Indramat Refu GmbH

Uracher Straße 91 • D-72555 Metzingen
Phone +49 (0) 71 23 / 9 69-0 • Fax +49 (0) 71 23 / 9 69-120





**NRTL
LISTED**

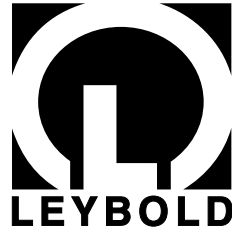

The system TURBOVAC TW 250 S / TURBO.DRIVE S, turbomolecular pump with frequency converter, has been tested by the TÜV Rheinland of North America according to the requirements of

- **NRTL**
(applied standards UL 3101-1/10.93)

It is in compliance to the tested standards.

NRTL Report No. E 9972082 E 01

Index

A

acceleration 28
adsorption trap 19, 23, 38
aggressive 5, 16, 35
airing 3, 11, 14, 22
altitude 16
ambient temperature 12, 16, 20, 21, 25, 39

B

bearing temperature 29, 32, 33, 39

C

clamping yoke 6, 19, 42
contamination 22, 38, 47
cooling 6, 8, 11-13, 20, 21, 24, 25, 39, 40

D

deceleration 17, 28
desiccant 6, 18, 37
direction of rotation 34
dust 5, 16, 18, 35

E

emergency shut down 35
error code 33, 39, 40

F

fan 6, 7, 21, 39
forevacuum connection 7, 12, 17, 19
forevacuum pressure 6, 12, 14, 20, 36, 39
forevacuum pump 5, 19, 23, 34-36, 39, 41
functional extra low voltage 3, 25

H

Hazardous gases 3, 5, 19, 37
heat sink 8, 10, 25, 44, 45
High-vacuum flange 3, 7, 17, 18, 20
Holweck 6
humidity 3, 12, 19, 22, 45

L

LED 3, 24, 28, 30, 34, 35, 37, 39-41
liquids 5

M

magnetic field 16
media 5, 16, 22, 35
motor current 25, 29, 32
motor temperature 29, 33, 39

N

Nitrogen 14, 20, 22

O

ON/OFF switch 10, 34

P

particles 35, 36
polarity 25, 40
power failure 3, 11, 14, 22, 35
purge gas 3, 6, 7, 12, 17, 22, 35, 38

R

Relay 12, 28, 29, 32
rotor 3, 6, 7, 16, 18, 29, 32, 34-36, 38, 41

S

splinter guard 8, 11, 17, 18
starting pressure 34

V

venting 3, 6, 7, 11, 12, 17, 22, 35, 36
vibrations 18, 19, 34, 41

W

water cooling 6, 8, 11, 12, 13, 20, 21, 39

Sales and Service Net Worldwide

EUROPE

Germany:

LEYBOLD VAKUUM GmbH
Bonner Straße 498 (Bayenthal)
D-50968 Cologne
e-mail:
sales@leyboldvakuum.com
Phone: +49-221-347 1234
Fax: +49-221-347 1245

LEYBOLD VAKUUM GmbH
SERVICE CENTER
Emil-Hoffmann-Strasse 43
50996 Cologne-Suerth
e-mail:
service@leyboldvakuum.com
Phone: +49-221-347 14 39
Fax: +49-221-347 19 45

Belgium:

LEYBOLD VACUUM
Nederland B.V.
Belgisch bijkantoor
Leuvensesteenweg 542, 9A
1930 Zaventem
e-mail: info@leybold.be
Sales:
Phone: +32-2-711 00 83
Fax: +32-2-720 83 38
Service:
Phone: +32-2-711 00 82
Fax: +32-2-720 83 38

France:

LEYBOLD VACUUM
FRANCE S.A.
7, Avenue du Quebec
Z.A. de Courtaboeuf, B. P. 42
91942 Courtaboeuf Cedex
e-mail:
leybold-vacuum@leybold.fr
Sales and Service:
Phone: +33-1-69 82 48 00
Fax: +33-1-69 07 57 38

Great Britain:

LEYBOLD VACUUM UK LTD.
Waterside Way, Plough Lane
London SW17 0HB
Sales:
e-mail: sales@leybold.co.uk
Phone: +44-20-8971 7000
Fax: +44-20-8971 7001
Service:
e-mail:
service@leybold.co.uk
Phone: +44-20-8971 7030
Fax: +44-20-8971 7003

Italy:

LEYBOLD VACUUM
ITALIA S.p.A.
8, Via Trasimeno
20128 Milano
Sales:
e-mail: sales@leybold.it
Phone: +39-02-27 22 31
Fax: +39-02-27 20 96 41
Service:
e-mail: service@leybold.it
Phone: +39-02-27 22 31
Fax: +39-02-27 20 96 41

Netherlands:

LEYBOLD VACUUM
NEDERLAND B.V.
Computerweg 7
3542 DP Utrecht
e-mail: mail@leybold.nl
Sales and Service:
Phone: +31-346-58 39 99
Fax: +31-346-58 39 90

Spain:

LEYBOLD VACUUM
ESPAÑA S.A.
C/ Mataró, 27
Polígono Industrial
Les Grases
08980 Sant Feliu de Llobregat (Barcelona)
e-mail:
leybold@leyboldspain.com
Sales:
Phone: +34-93-666 46 16
Fax: +34-93-666 43 70
Service:
Phone: +34-93-666 49 51
Fax: +34-93-685 40 10

Sweden:

LEYBOLD VACUUM
SCANDINAVIA AB
Box 9084
40092 Göteborg
e-mail: info@leybold.se
Sales and Service:
Phone: +46-31-68 84 70
Fax: +46-31-68 39 39

Switzerland:

LEYBOLD VAKUUM
SCHWEIZ AG
Leutschenbachstrasse 55
8050 Zürich
e-mail: sales@leybold.ch
Sales:
Phone: +41-1-308 40 50
Fax: +41-1-302 43 73
Service:
Phone: +41-1-308 40 62
Fax: +41-1-302 43 73

AMERICAS

USA:

LEYBOLD VACUUM USA INC.
5700 Mellon Road
Export, PA 15632
e-mail:
info@leyboldvacuum.com
Sales:
Eastern & Central time zones
Phone: +1-724-327-5700
Fax: +1-724-733-1217
Pacific, Mountain,
Alaskan & Hawaiian time zones
Phone: +1-480-752-9191
Fax: +1-480-752-9494

Service:
Phone: +1-724-327-5700
Fax: +1-724-733-3799

ASIA

P.R. China:

LEYBOLD VACUUM
(Tianjin)
International Trade Co., Ltd.
Beichen Economic Development Area (BEDA), Tianjin, 300400, China.
Phone: +86-22-26970808
Fax: +86-22-26974061,
Fax: +86-22-26972017
E-mail:
leybold@leybold.com.cn

LEYBOLD (Tianjin)
VACUUM Equipment Manufacturing Co. Ltd
Beichen Economic Development Area (BEDA), Tianjin, 300400, China.
Phone: +86-22-26970808
Fax: +86-22-26974061
Fax: +86-22-26972017
E-mail:
leybold@leybold.com.cn

LEYBOLD VACUUM
(Tianjin)
International Trade Co., Ltd.
Shanghai Branch:
Add: No.33, 76 Futedong San Rd., Waigaoqiao FTZ, Shanghai, 200131, China.
Phone: +86-21-5064-4666
Fax: +86-21-5064-4668
E-mail:
leybold_sh@leybold.com.cn

LEYBOLD (Tianjin)
VACUUM Equipment Manufacturing Co.Ltd.
Guangzhou Branch:
Add: G/F,#301 Building, 110 Dongguangzhuang Rd, Tianhe District, Guangzhou 510610, China.
Phone: +86-20-8723-7873
Phone : +86-20-8723-7597
Fax: +86-20-87237875
E-mail:
leybold_gz@leybold.com.cn

Japan:

Sales:
LEYBOLD VACUUM
Japan Co., Ltd.
Head Office
Tobu A.K.Bldg.
4th Floor 23-3,
Shin-Yokohama 3-chome
Kohoku-ku, Yokohama-shi
Kanagawa-ken 222-0033
Phone: +81-45-4713330
Fax: +81-45-4713323

Sales:
LEYBOLD VACUUM
Japan Co., Ltd.
Osaka Branch Office
MURATA Bldg.7F
2-7-53, Nihi-Miyahara, Yodogawa-ku
Osaka-shi 532-0004
Phone: +81-6-6393-5211
Fax: +81-6-6393-5215

Service:
LEYBOLD VACUUM
Japan Co., Ltd.
Tsukuba Technical S.C.
Tsukuba Minami Daiichi
Kogyo Danchi
21, Kasumi-no-Sato,
Ami-machi nashiki-gun
Ibaraki-ken, 300-0315
Tel.: +81-298-89-2841
Fax: +81-298-89-2838

Korea:

LEYBOLD VACUUM
Korea Ltd.
#761-47, Yulkeum-ri,
SungHwan-eup, Chonan
Choongchung-Namdo,
330-807, Korea
Sales:
Tel.: +82-41-580-4431
Fax: +82-41-588-3737
Service Center:
Phone: +82-41-588-3765
Fax: +82-41-588-3769

Singapore:

LEYBOLD VACUUM
Singapore Pte Ltd. No.1,
International Business Park,
B1-20B, The Synergy
Singapore 609917
Phone: +65-66652910
Fax: +65-65668202
vacuum@leyboldvac.com.sg

Taiwan:

LEYBOLD VACUUM
Taiwan Ltd.
2F, No 416-1, Sec.3
Chung-Hsin Rd., Chu-Tung
Hsin-Chu, Taiwan, R.O.C.
Phone: +886-3-5833988
Fax: +886-3-5833999



LEYBOLD VAKUUM GmbH

Bonner Strasse 498 (Bayenthal)
D-50968 Cologne

Tel.: + 49 221 347-0
Fax: + 49 221 347-1250
<http://www.leybold.com>
e-mail: documentation@leyboldvac.de